

Downstream Defender[®] Advanced Hydrodynamic Vortex Separator

The Downstream Defender[®] is an advanced hydrodynamic vortex separator for the effective and reliable removal of fine particles, oils and other floatable debris from surface water runoff.

Its innovative design delivers high efficiency across a wide range of flows in a much smaller footprint than conventional or other swirl-type devices and it is the perfect choice for any catchment likely to convey high quantities of contamination.

1. Access for removal of floatables and sediments.
2. Inlet pipe.
3. Inlet chute.
4. Centre shaft.
5. Dip plate.
6. Centre cone.
7. Benching skirt.
8. Floatables and oil storage.
9. Isolated sediment storage zone.
10. Outlet pipe.

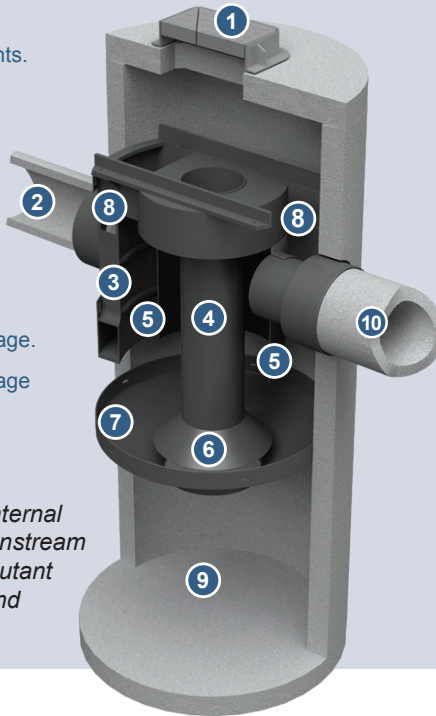

Unique Flow Modifying Components

The Downstream Defender[®] consists of a structural concrete chamber with unique flow modifying internal components. It is these internal components that differentiate the Downstream Defender[®] from catchpits, sedimentation basins or sedimentation sumps. They facilitate advanced hydrodynamic vortex separation by reducing turbulence, lengthening the flow path to increase chamber residence time and introducing shear planes.

The internal components also ensure that the pollutant storage zones are isolated and protected from high flows that could cause pollutant re-entrainment or wash out.

Compared to devices that have poorly designed internal components, the Downstream Defender[®] captures and retains more of the annual pollutant load.

Watch a short video showing the Downstream Defender[®] components and operation at:

<http://www.hydro-int.com/uk/products/downstream-defender>



Figure 1 - The unique internal components of the Downstream Defender[®] enhance pollutant removal performance and prevent wash out.

Repeatable, Reliable Performance

The Downstream Defender[®] delivers high removal of pollutants through advanced, hydrodynamic separation across a wide range of flows. The device has a proven track record of tackling an assortment of pollutants including:

Fine particles



Greater than 80% removal of fine sand particles.

See Technical Abstract: Performance Verification of Fine Sediment Removal with US Silica OK-110.

Gross Pollutants



100% of floatable debris, such as food wrappers, Styrofoam cups and drinks cartons removed in independent site trials.

Liquid and Sediment Bound Hydrocarbons



Greater than 50% removal of various forms of hydrocarbons, including free floating oils and polycyclic aromatic hydrocarbons (PAHs).

See Technical Abstract: Removal of Hydrocarbons.

Sediment Bound Heavy Metals and Nutrients



As an efficient device for removal of fine sediment, the Downstream Defender[®] is also effective for removal of sediment bound pollutants.



See Technical Abstract: Pollutant Removal Through Association with Sediments.

Design Data

Downstream Defender®

Advanced Hydrodynamic Vortex Separator

No Risk of Pollutant Wash Out

The Downstream Defender® has been specially designed to isolate the pollutant storage zones and is proven to prevent pollutant wash out. See Technical Abstract: The Importance of Pollutant Wash Out Protection.

Sizing

The Downstream Defender® can be sized for different treatment goals and objectives.

For design purposes, the selected model's Treatment Flow Rate should be greater than or equal to the site's Water Quality Flow Rate.

The hydraulic capacity of the selected model should be considered with respect to the peak discharge flow rate from the site.

Model Diameter (m)	Treatment Flow Rate (l/s) ^{a)}	Hydraulic Capacity (l/s) ^{b)}	Oil Storage Capacity (l)	Sediment Storage Capacity (m ³)
1.2	42	120	270	0.7
1.8	119	300	1350	1.7
2.55	150	600	2500	3.8
3.0	250	750	4650	4.4

Notes:

- a) Treatment flow rates based on >80% removal of US Silica Sand OK110 with no flow bypass. Sizing based on removal of finer or coarser sediment ranges or for free oil removal can be provided if required.
- b) Maximum flow rate that can pass through the chamber without surcharge to the upstream network.

Head loss at the treatment flow rate is typically less than 150 mm.

Table 1 - Downstream Defender® design information.

Expert Design Service

Hydro's professional engineers are on hand to provide free support with the correct sizing and selection of the Downstream Defender® within each drainage design.

We can also provide estimated maintenance intervals, whole life cost estimates and predicted pollutant removal performance.

Call the StormTrain® Hotline on: 01275 337955 or email stormtrain@hydro-int.com

Setting Out

The Downstream Defender® can accommodate a change in pipe direction to suit site specific requirements. Combined with the high rate internal bypass, this helps to avoid the need for additional manholes on site. Head loss across the chamber is kept to a minimum (see Table 1).

The inlet and outlet pipes should be sized in accordance with Table 2 (opposite), and a minimum of 90 degrees between inlet and outlet is required.

Inlet and outlet pipe connections are at the same invert level.

Additional manhole sections can be provided to extend the chamber to meet site cover and invert levels or provide additional pollutant storage where required.

Design Data

Downstream Defender®

Advanced Hydrodynamic Vortex Separator

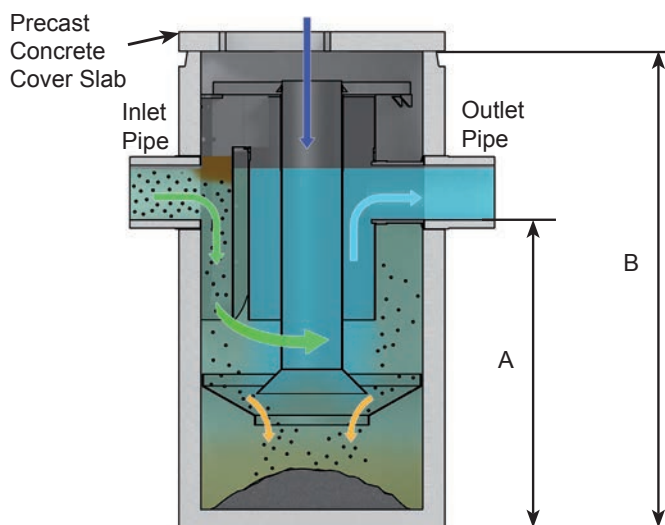
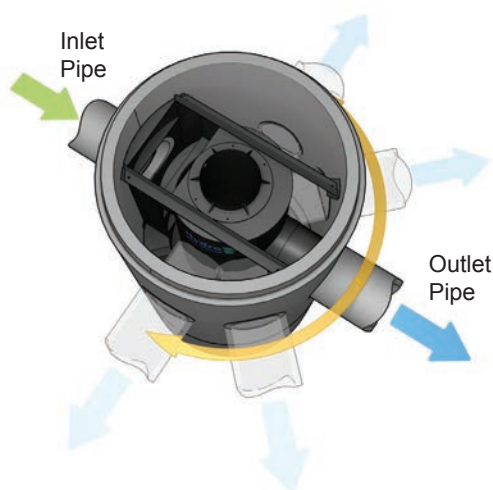

Dimensions and Weights

General arrangement drawings of all units are available for download from:

<http://www.hydro-int.com/uk/products/downstream-defender>

Unit	External Diameter of Unit (mm)	Inlet & Outlet Pipe Diameter (mm)	Depth (m)			Lift Weight (t)
			A	B	Component Depth ^{a)}	
1.2 m Sealed Manhole System with HD Cover Slab	1460	300	1.910	2.600	2.830	
HD Cover Slab ^{b)}					0.230	0.6
Base Section					0.825	1.5
Top Section					1.765	2.5
1.8 m Sealed Manhole System with HD Cover Slab	2160	450	2.510	3.800	4.050	
HD Cover Slab ^{b)}					0.290	1.4
Base Section					1.235	5.0
Top Section					2.485	8.0
2.55 m System with HD Cover Slab	2850	600	2.950	4.750	4.950	
HD Cover Slab ^{b)}					0.200	2.8
Base Section					1.750	8.0
Top Section					3.000	10.0
3.0 m System with HD Cover Slab	3350	750	3.125	5.000	5.200	
HD Cover Slab ^{b)}					0.200	4.6
Base Section					2.000	12.5
Top Section					3.000	14.0

Notes:

a) Base and Top Section component depths are shown as the total height during transportation / before assembly on site. The total depth is the depth of the assembled unit.

b) Cover slabs are heavy duty, suited for highways loading and are supplied with one or two access openings for maintenance.

c) Inlets and outlets are supplied with cast-in holes only. No stub pipes are provided.

Dimensional Tolerances: Height \pm 25 mm; Diameter \pm 12 mm; Wall Thickness \pm 10 mm

Table 2 - Downstream Defender® dimensions and weights.

Design Data

Downstream Defender®

Advanced Hydrodynamic Vortex Separator

Easy to Install

The Downstream Defender® is typically delivered to site as a precast concrete manhole with internal components already installed. Installation is therefore similar to any other manhole installation on site. Full installation guidelines are available.

Lightweight High Density Polyethylene (HDPE) chambers can be provided where installation of a concrete manhole is not practical.

Easy to Maintain

Maintenance of the Downstream Defender® is simple, safe and cost-effective. Maintenance is carried out from the surface, using a standard vacuum tanker and personnel are not required to enter the device.

With a large capacity to store sediments and oils (see Table 1), and with a proven ability to prevent wash out, maintenance intervals can be years rather than months - depending on site conditions.

Additional pollutant storage can be built into the chamber to extend maintenance intervals if required.

Watch a short video showing the Downstream Defender® maintenance at:

<http://www.hydro-int.com/uk/products/downstream-defender>



Downstream Defender® Technical Guidance



Technical Abstracts



Case Studies



Installation and Maintenance Guidelines

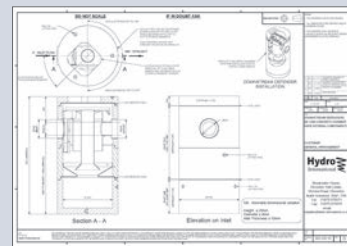

General Arrangement Drawings

The Hydro StormTrain® Series of Surface Water Treatment Devices

The Downstream Defender® is one of the Hydro StormTrain® Series of surface water treatment devices. Each device delivers proven, measurable and repeatable surface water treatment performance. Each can be used independently to meet the specific needs of a site or combined to form a management train. They can be used alongside natural SuDS features to protect, enable or enhance them.

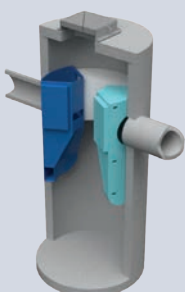

First Defense®
Vortex Separator

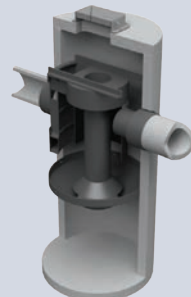

Downstream Defender®
Advanced Hydrodynamic
Vortex Separator

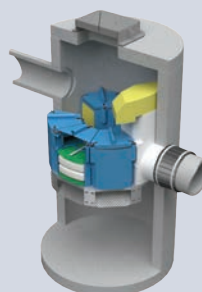

Up-Flo™ Filter
Fluidised Bed Up Flow
Filtration System



Hydro BioCell™
Bioretention System