



Pipeline & Drainage Systems Ltd



EnviroChannel

The recycled one-piece channel drain solution

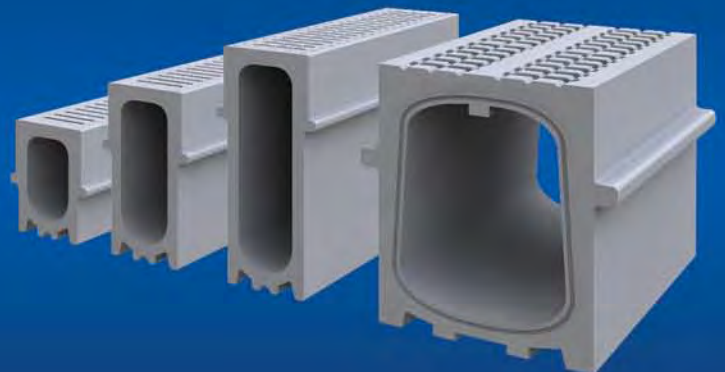

Tel: +44 (0) 844 848 9400

Web: www.pds-plc.com

WELCOME TO PDS

A reputation built through innovation

Pipeline & Drainage systems are the market leaders in innovative kerb, channel & bridge drainage products. Since 2000, we have helped hundreds of clients meet the complex drainage requirements of their projects with solutions that continue to stand the test of time.

Our unique designs and materials are second-to-none and our products are accredited, guaranteed and supported by the most comprehensive installation guidelines in the industry.

We guarantee excellence in design, products and service for every customer.

EnviroChannel

The one-piece linear channel drainage system



Envirochannel is made from a recycled material that is lightweight, strong and better for the environment.

[Read more about Envirochannel Features & Benefits \(Pages 4-5\)](#)

Envirochannel is the optimum drainage system for schemes ranging from supermarkets and industrial areas to highways and architectural schemes. We also produce high capacity units and specialised units for petrol station forecourts.



PDS are proud to be part of the RMP global group of brands. RPM specialise in high-performance coatings, sealants and speciality chemicals. RPM products are sold in approximately 150 countries and territories.

As part of RPM, PDS are able to draw upon unparalleled levels of expertise to provide the most complete solution for the individual needs of our customers.



[Retail Installation \(Pages 6-7\)](#)

[Architectural Schemes \(Pages 8-9\)](#)

[Highways & Infrastructure \(Pages 10-11\)](#)

[Industrial Schemes \(Pages 12-13\)](#)

[Petrol Station Forecourts \(Pages 14-15\)](#)

EnviroKerb

Combined Kerb Drainage System

Envirochannel can be used in conjunction with Envirokerb - the one-piece combined kerb drainage solution. More and more contractors are turning to Envirokerb with more than one million units laid in projects across the UK and beyond. The Envirochannel and Envirokerb systems are fully compatible to meet the requirements of even the most complex schemes.



The extensive product range is fully supported by our design services and comprehensive installation guidelines. All our products are accredited and guaranteed against breakage.

[Product Range \(Pages 16-17\)](#)

[Installation Guide \(Pages 18-19\)](#)

[Design Services \(Page 20\)](#)

Features & Benefits

Strong & Robust



Envirochannel **does not break**. The units are made from a recycled material that is stronger than concrete and certified to class **D400 kN**. The units can be left exposed during the construction phase with no danger of breakage.

Lightweight



Unit weights in the range of 9-19kg means Envirochannel can be installed with **one-man manual lift** for ease of installation and reduced Health & Safety risks.

Durable



Envirochannel is **resistant** to all forms of effluents including road salts, petrol, and diesel. The units **do not rust** and maintain their finish during and after installation.

Cost Savings



The material cost, construction depth and installation time is reduced when compared with traditional systems.

One-Piece Design



Traditional units often fail at the join of the metal grate with the concrete channel. Envirochannel's one-piece design ensures the load is distributed evenly with **no danger of failure**.

A Channel Like No Other



Confusion over the loading requirements of channel drainage means that broken units are all too common. That's why PDS designed Envirochannel - the strongest product on the market and certified to a minimum of **D400kN** for all types of loading. Turning? Braking? Reversing? No problem - Envirochannel has been designed for all situations.

Full Product Range



- Standard unit width of **100mm** and depth of **180, 260 or 380mm** (intermediate depths also available).
- Slot options of 10mm and 6mm
- Interception grating for containment areas such as forecourts.
- Range of **outlet options** including gully units, rodding units and silt boxes.
- Available in Black, Concrete Grey and Charcoal

High Capacity Unit



High Capacity Unit (**200mm** wide by **355mm** deep) available for areas requiring high containment.

Better for the Environment



Unlike existing systems - which are brittle, heavy and difficult to recycle - Envirochannel can help to reduce the carbon footprint of your organisation.

Envirochannel is manufactured from a **recycled plastic** composite that would otherwise be destined for landfill in the UK and overseas.

The units are robust and **do not break** during or after installation. At the end of their lifetime they can even be recycled into new units.

All this reduces the amount of waste sent to landfill in the UK or overseas and helps to meet the increasing **recycling demands** of the industry.



Guaranteed



We are so confident of Envirochannel's ability to provide a strong, robust and lasting drainage solution that we offer a **guarantee against breakage** - before, during and after installation.

GUARANTEE

Accredited & Certified



Envirochannel meets all your legal and regulatory requirements and the units are fully guaranteed.

- Fully compliant with **BS-EN1433**
- All units meet load classification **D400 kN** with E600 kN for the 200mm system
- Carries the **CE** mark of conformity
- Carries the **LRQA** Product Certification Mark

Easy to Install

The high impact strength means the units can be hammered to line and level. The light weight allows one-man manual lift. The bed and haunch size are often reduced. All this gives a much faster installation phase and less restriction across site.



High Strength Units

Envirochannel is able to withstand all loadings expected in a retail environment, both front and back of store. Envirochannel is **durable and resilient** even during the construction phase.



Outlet Options

Envirochannel units require little maintenance - and a range of silt boxes, gully outlets and rodding units complement the system to provide easy access for cleaning when required.



Superior Load Performance

Envirochannel's unique material and monolithic design provides a strong and robust unit that distributes the load throughout the unit and delivers a true performance of **D400 / E600 kN** .

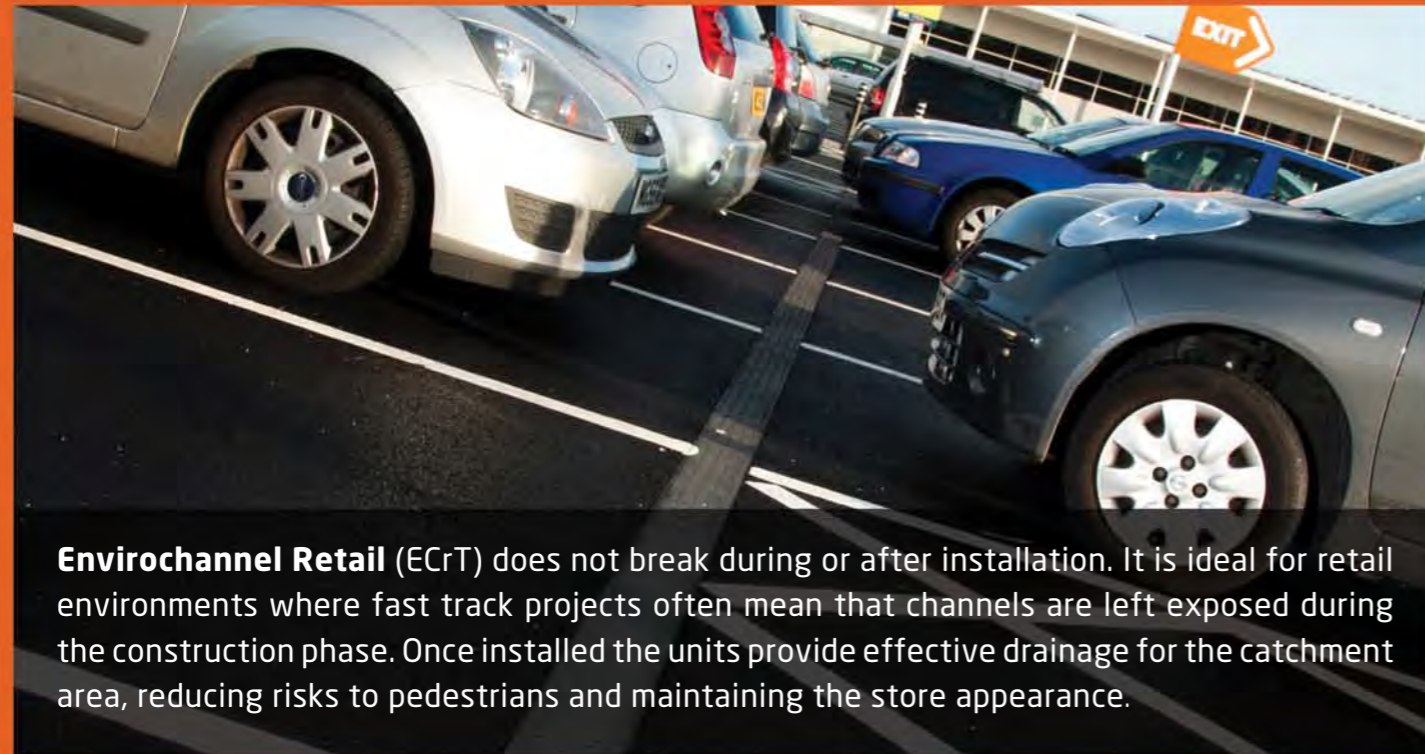

Envirochannel Retail (ECrT) does not break during or after installation. It is ideal for retail environments where fast track projects often mean that channels are left exposed during the construction phase. Once installed the units provide effective drainage for the catchment area, reducing risks to pedestrians and maintaining the store appearance.



Product Specification

	Dimensions (mm)			Weight (kg)	Inlet Options	
	W	D	L		Heel-Friendly-6mm	10mm
EC180rT	100	180	500	9	✓	✓
EC260rT	100	260	500	13	✓	✓
EC380rT	100	380	500	19	✓	✓
EC355rT	200	355	500	29		15mm

Colour Options: Black, Grey, Charcoal, Others Made to Order

Accredited & Certified

- Fully compliant with European Standard **BS-EN1433**
- Meets load classification **D400 kN** (100mm units) and **E600 kN** (200mm units)
- Carries the **CE** mark of conformity
- **LRQA** Product Certification Mark
- **Guaranteed against breakage** - before, during and after installation



Envirochannel in the Car Park

PDS supplied 260 metres of D400 Envirochannel units for a Tesco store, car park and loading bay area in Ashford, Kent.

"We were able to install Envirochannel much more quickly than concrete units. There were no breakages on site during construction and no damage since then. We like the design and we like the price!"

- Eddie Greene, Site Manager for Gallagher Contractors.

High Quality Finish

Envirochannel is made from a 100% recycled, composite material that is manufactured to a **high quality** finish. The units can be supplied in a **range of colours** to enhance your scheme appearance - for example to delineate road edges or to match surrounding construction materials.

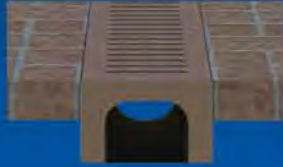

Precision Manufactured

Envirochannel units can be cored, shaped and splayed on site to meet the **precision design** of your scheme. PDS can supply pre-fabricated angles, junctions, and even **bespoke special features** such as faceted radii to exactly match your design requirements.



Does Not Degrade

Rusty grates and oil stains are a familiar sight in many public areas. But Envirochannel units **do not rust**, are **resistant** to oil, petrol and road salts, require little ongoing maintenance and will maintain their appearance for many years.



Linear System

Envirochannel is a true **linear system** with a common width across all access and outlet units. The overall effect is more subtle and discreet than traditional systems that require special cuts or block inserts.



ARCHITECTURAL SCHEMES



Envirochannel Architectural (ECvA) provides the ideal solution for projects where visual appearance is important. From large shopping precincts to pedestrianised public spaces Envirochannel provides longevity and strength without compromising the high aesthetic quality of your scheme.



Product Specification

	Dimensions (mm)			Weight (kg)	Inlet Options	
	W	D	L		Heel-Friendly-6mm	10mm
EC180vA	100	180	500	9	✓	✓
EC260vA	100	260	500	13	✓	✓
EC380vA	100	380	500	19	✓	✓
EC355vA	200	355	500	29		15mm

Colour Options: Black, Grey, Charcoal, Others Made to Order

Accredited & Certified

- Fully compliant with European Standard **BS-EN1433**
- Meets load classification **D400 kN** (100mm units) and **E600 kN** (200mm units)
- Carries the **CE** mark of conformity
- **LRQA** Product Certification Mark
- **Guaranteed against breakage** - before, during and after installation



Envirochannel on the High Street

For the redevelopment of Perth High Street, the appearance of Envirochannel was as important as the performance and the price.

"We needed the channel to complement the design not detract from it. PDS supplied the units in a colour that perfectly matches the surrounding granite, and at a much lower cost than concrete units. Both the architect and the contractor couldn't be happier with the finish."

- Stewart McGregor, Project Manager for Perth & Kinross Council

Safe for Pedestrians

Envirochannel's unique material properties and one piece design provide a solid, **non-rocking** construction with no removable parts suitable for areas subject to pedestrian footfall.



Slot Options

A choice of slot options are available for pedestrian areas, carriageways, and PPE areas. An additional linear slot option (iG slot) is available where improved catchment from the surface is needed.



Enhanced Installation Detail

For the most challenging environments a more robust detail can be achieved using dowels, reinforcement or an extra foundation support to strengthen the surrounding haunch.



Low Maintenance

The one-piece design of Envirochannel eliminates the danger of **lost, stolen or loose grates** and reduces the need for ongoing maintenance required with traditional systems.



Envirochannel Highway (EChW) is a 100% recycled and recyclable surface drainage system specifically designed for use on motorways, carriageways and areas subject to frequent and fast moving traffic. Envirochannel meets the essential requirements of safety, strength, durability and low maintenance as well as fulfilling EN1433 and HA compliance.



Product Specification

	Dimensions (mm)			Weight (kg)	Inlet Options		
	W	D	L		6mm	10mm	iG slot
EC180hW	100	180	500	9	✓	✓	Made to Order
EC260hW	100	260	500	13	✓	✓	Made to Order
EC380hW	100	380	500	19	✓	✓	Made to Order
EC355hW	200	355	500	29		15mm	✓

Colour Options: Black, Grey, Charcoal, Others Made to Order

Accredited & Certified

- Fully compliant with European Standard **BS-EN1433**
- Meets load classification **D400 kN** (100mm units) and **E600 kN** (200mm units)
- Carries the **CE** mark of conformity
- **LRQA** Product Certification Mark
- **Guaranteed against breakage** - before, during and after installation



Envirochannel on the Buses

Over 500 Envirochannel units were supplied to the Arriva Bus Depot at Speke in Liverpool.

"The site is busy 24 hours a day so we had to install the channel in sections with some runs left exposed during construction, but we experienced no breakages. We've already specified them for another of our depots."

- David Wilkinson, Project Manager, Arriva Plc.

Traditional Channel Failure

Traditional two-piece linear drainage commonly fails at the point where the load is transferred from the grate to the channel wall. Units rated at D400 under BSEN1433 often fail in this way on site, leading many designers to upgrade to E600 or F900 units, at the expense of the correct system.



Envirochannel Does Not Fail

Envirochannel's one-piece design and flexible strength distributes the load throughout the unit, eliminating the risk of channel failure and delivering a true D400/ E600 solution equal to a similarly rated access cover and frame.

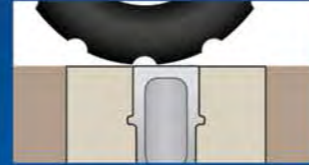

Robust During Construction

Envirochannel has the inherent strength under load to withstand loading even when left exposed during the construction process. This improves access to the site and minimises damage.



Does Not Crack

Envirochannel keys into the surrounding surface to reduce movement under load and avoid cracking of the surrounding structure. The system has no moving sections, eliminating the risk of loose or missing parts.



INDUSTRIAL SCHEMES



Envirochannel Industrial (EChD) is the ideal system for service yards and loading areas where compliance, load performance and longevity are essential. Envirochannel provides all the same benefits as traditional grated systems but the one-piece solid design provides a more robust solution under loading.



Product Specification

	Dimensions (mm)			Weight (kg)	Inlet Options		
	W	D	L		6mm	10mm	iG slot
EC180hD	100	180	500	9	✓	✓	Made to Order
EC260hD	100	260	500	13	✓	✓	Made to Order
EC380hD	100	380	500	19	✓	✓	Made to Order
EC355hD	200	355	500	29		15mm	✓

Colour Options: Black, Grey, Charcoal, Others Made to Order

Accredited & Certified

- Fully compliant with European Standard **BS-EN1433**
- Meets load classification **D400 kN** (100mm units) and **E600 kN** (200mm units)
- Carries the **CE** mark of conformity
- **LRQA** Product Certification Mark
- **Guaranteed against breakage** - before, during and after installation



Envirochannel on the Grid

1000 metres of Envirochannel and Envirokerb units were used for a National Grid sub-station in Harker, Carlisle.

"We needed a channel that gave superior load performance, didn't rust, and provided high capacity in case of fuel spills. Envirochannel has not only delivered on all counts but has even helped us save money. The fact it's recycled is the icing on the cake."

- Rob Taylor, Site Agent for Trant Construction

Catchment and Containment

Envirochannel ECiG is produced with secondary **trans-linear slots** that prevent migration of fluid across the channel width, dispersing excess along the run.



High Capacity

Envirochannel is designed with sufficient capacity to cater for a range of flow speeds at each stage, from catchment right through to the final collection point. High capacity units are also available with the iG slot.



Minimises Contamination

Cracking of the surrounding structure and movement at the joints are the main causes of contamination in traditional systems. Envirochannel's flush joints allow each unit to be compacted during installation ensuring a **robust construction** that sits well within the surrounding structure.



Watertight System

Unlike traditional systems the sealant is applied to the two vertical faces and squeezed across the joint during compaction providing a **100% watertight seal** as stipulated under BS-EN1433.



PETROL STATION FORECOURTS



Envirochannel Interception Grating (ECiG) is a 100% recycled and recyclable surface drainage system specifically designed for petrol forecourts and fluid containment areas, where the system must not only cope with day-to-day surface run off but also collect, contain and discharge high volume spillages.



Product Specification

	Dimensions (mm)			Weight (kg)	Inlet Options		
	W	D	L		6mm	10mm	iG slot
EC180IG	100	180	500	9	✓	✓	Made to Order
EC260IG	100	260	500	13	✓	✓	Made to Order
EC380IG	100	380	500	19	✓	✓	Made to Order
EC355IG	200	355	500	29		15mm	✓

Colour Options: Black, Grey, Charcoal, Others Made to Order

Accredited & Certified

- Fully compliant with European Standard **BS-EN1433**
- Meets load classification **D400 kN** (100mm units) and **E600 kN** (200mm units)
- Carries the **CE** mark of conformity
- **LRQA** Product Certification Mark
- **Guaranteed against breakage** - before, during and after installation



Envirochannel on the Forecourt

For Spar Petrol Station forecourt in Ballyclare, Co. Antrim, the drainage solution had to provide highly effective containment in the event of spillage whilst maintaining the surface integrity of the surrounding structure.

"Envirochannel has proved to be the ideal solution at a very competitive price. Any issues we had on site were quickly addressed by the team at PDS and we'll certainly be specifying the same product on future schemes."

- Ashley Lamont - Whittaker & Watt Architects

Standard Dimensions

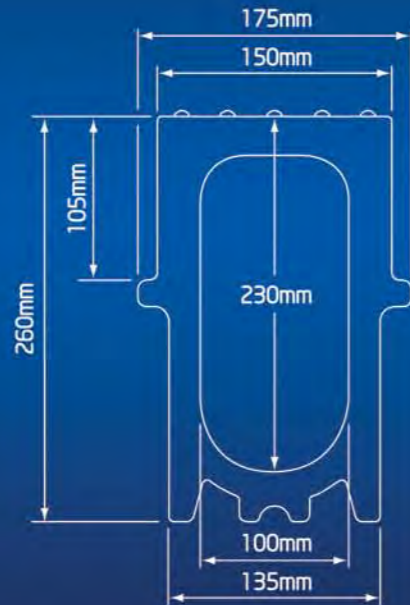

6mm - Heel-Friendly Slot



10mm - Standard slot



iG - Interception grating



Envirochannel standard depths are **180**, **260** and **380mm** with intermediate depths also available. The range encompasses end outlets, rodding units, silt boxes and gully units - everything you need for the complete drainage solution.

High Capacity Units

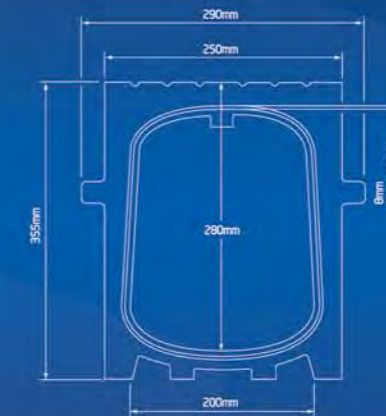

15mm - iG grating as standard



Envirochannel High Capacity units have a width of **200mm** for increased capacity where highly effective catchment and containment are required. The units come in a standard depth of **355mm**, with specialised outlet units also available.

Interception Grating - standard width

Interception Grating units are ideal for petrol stations where heavy liquid flow must be disrupted to prevent migration across the channel.



Rodding Unit - standard width

For ease of access during maintenance. Usually placed at no more than 40 metre centres, but also at start of runs and at angles.



Interception Grating - high capacity

Our high capacity channel is manufactured with the intercept pattern as standard for improved surface catchment.



Rodding Unit - high capacity

A robust one piece unit that enables access for a thorough clean through of the system as and when required.



Gully Unit - standard width

Purpose made gully assembly that can be used in conjunction with our full range of Envirochamber components.



Silt Box

Common unit across the range which can accommodate outlets in either end or side positions.



Gully Unit - high capacity

A purpose made large volume discharge point offering a range of connection options.



Manhole Chambers

Envirochannel fully integrates with our range of one-piece, recycled manhole chamber sections for a complete drainage solution.



Installation Benefits

Envirochannel has several advantages over two-piece channels making it quick and easy to install.

The units can be **left exposed** during the construction phase with no danger of failure under loading.

The **lightweight units** can be handled manually on site with a reduced health and safety risk.

The **one-piece design** and composite material allows the units to be tapped to line and level.

The amount of bedding and haunch material is **significantly reduced** in comparison to concrete units.

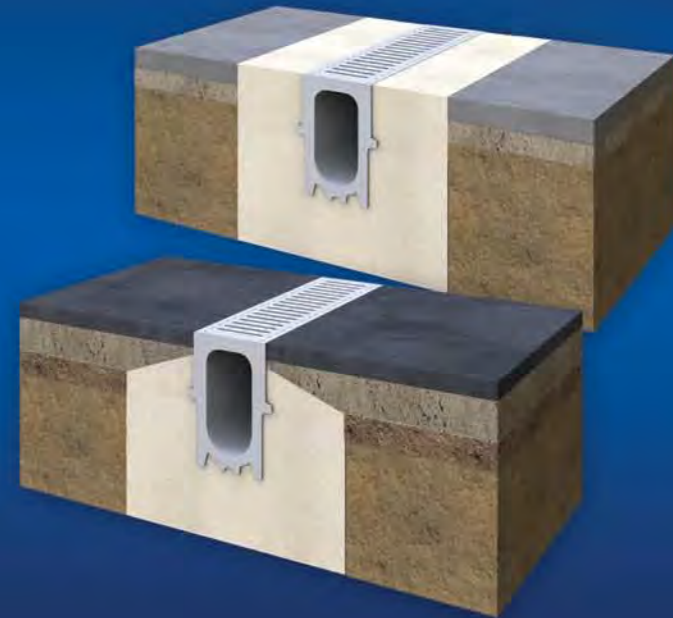

IPAC Online Guide

Our **Installation Programme for Advice & Compliance (IPAC)** is a unique online tool offering detailed step-by-step guidelines for installing our products.

When you specify our products we will send you a link to access our **video guides** and register you for our approval scheme.

For designers this ensures the scheme is built as specified. For contractors it means the installation will be robust and our products are **guaranteed** against breakage.

For more information visit www.pds-plc.com/ipac



Design Services

Free schematic design service by PDS

PDS offer a free design service to ensure your drainage system meets the requirements for your scheme. We are able to advise on hydraulic flows and help select the most cost-effective and hydraulically efficient drainage units.

Send us a copy of your project schematic and we will mark it up with our recommended solution, including hydraulic calculations and recommended products. The scheme will be made available to you online using our Schemebuilder interactive tool where you can view or print it for reference.



Installation Guide - for full details visit www.pds-plc.com/ipac

Step 1 - Layout units along run length prior to installation to ensure all rodding units and outlets are positioned correctly.

Step 2 - Create trench by cutting into an existing surface or by using metal shutters. The trench width is 450mm and the depth is equal to the height of the unit plus 150mm for the race plus a small tolerance for bedding mortar.

Step 3 - Pour a concrete race of 150mm into the base of the trench. An ST4 mix with a 50mm slump is the minimum requirement.

Step 4 - Wait until the race has set before laying the units to achieve a level finish. A thin bedding mortar may be required. Alternatively a wet lay is possible if the concrete is of sufficient solidity to ensure the channel remains in line and level.

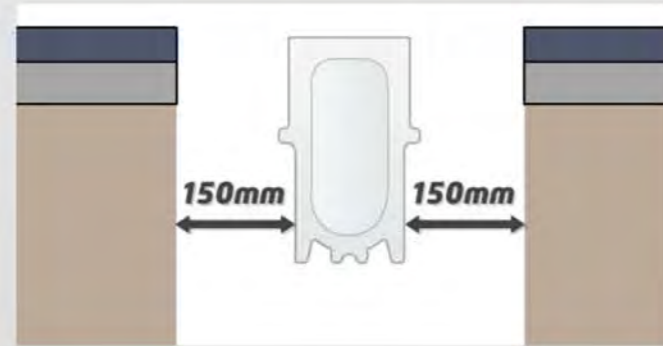

Step 5 - Adjoining units should be sealed with gun-applied Envirochannel sealant to meet the requirements of BSEN1433.

Step 6 - Pour a supporting haunch of 150mm width on either side of the units. The depth of the haunch will depend on the surface material. See our online IPAC guide for specific requirements for your scheme.

Step 7 - We recommend a 3-5mm overbuild is included where possible to deter lateral load impact from travelling vehicles and to ensure catchment at the lowest point.

In some cases a more robust detail should be considered. Incorporating dowels, reinforcement or an added foundation will help to improve the strength of the haunch and race. In these cases the interface between the channel and the structure must allow for contraction/expansion.

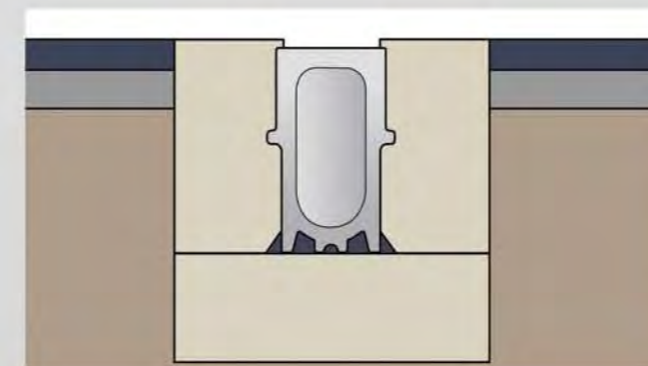

Specification Clause

The linear drainage shall be the Envirochannel system. The one-piece units shall have an integral grating with slot width of 10mm or 6mm (or iG pattern where necessary). The system shall be compliant with BSEN1433 Load Class D400KN/E600kN. The system shall be manufactured from recycled materials. Units are to be under 18kg (100mm wide) or 25kg (200mm wide) to comply with manual handling and health and safety regulations

System depths and layouts shall be in accordance with the contract drawings. All components shall be from the Envirochannel range including silt trap or gully unit outfalls. Rodding access units to be provided at no more than 40 metre centres. In accordance with BSEN1433 all linear channels should be made watertight through the application of Envirochannel sealant to each unit during the installation process.

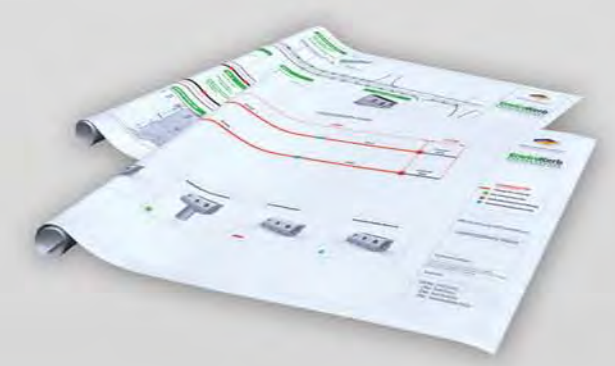

CPD Seminars

PDS are pleased to offer free presentations to engineers. Working closely with design engineers ensures that the correct sizes of systems are installed and we gain valuable on-going feedback to assist us in our policy of continuous product development.

A Proven Solution

Envirochannel is the drainage system of choice for more and more high profile projects across the UK and beyond. From car park supermarkets to your local high street, from industrial yards to petrol station forecourts, Envirochannel is the ideal solution for designers, contractors and clients, delivering multiple benefits for your scheme. The sight of broken units is a thing of the past because Envirochannel does not break before, during or after installation - and that's **guaranteed**.

National Cycling Centre, Manchester

For this prestigious project the final appearance is important. Envirochannel was chosen as it is rust free, easy to clean and the quality finish complements the existing textured walkways.



Alde Distribution Centre, Northants.

High Capacity Envirochannel can cope with heavy loading and the intercept grating is perfect for large volume spillages, making it the perfect unit for this industrial area.



Travelodge Hotel, Enfield, London

Envirochannel is ideal for areas open to pedestrian access such as this car park. The units are durable and robust even when left exposed during the construction phase as shown here.



For more case studies and to access our free suite of design tools, installation guides and services visit

www.pds-plc.com



PIPELINE & DRAINAGE SYSTEMS LTD

Head Office: Panama House, 184 Attercliffe Road, Sheffield, S4 7WZ
Tel: +44 (0) 844 848 9400 Fax: +44 (0) 844 848 9401

www.pds-plc.com

Registered No: 3787712 (England)

Envirokerb, Envirochannel and Envirodeck are a Registered Trademark.

PDS operates a policy of continuous development and whilst the enclosed specification is correct at time of publication, we reserve the right to change it without notice.



Design, Manufacture and Distribution
of Specialist Bridge and Kerb Drainage Products.