



PIPELINE & DRAINAGE SYSTEMS PLC

DEVELOPING PIPELINE & DRAINAGE SOLUTIONS



SubSurfaceChannelBridgeDrainageSystem FullyCompliantToBSEN1433HABA26/94

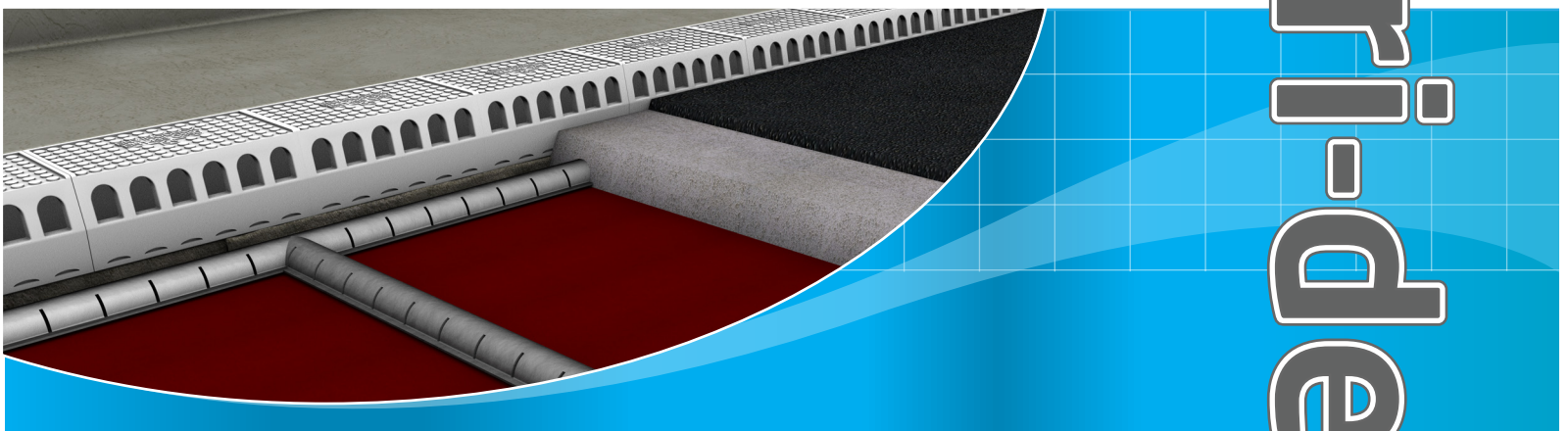

Dri-deck

- Sub Surface Drainage Channel System c/w Through Deck Outlets Provides additional and Lower sub Surface Water Collection
- Used with Envirodeck/Hydrodeck Combined Kerb Drainage Systems
- Wide Range of System Components - Angles /Tees/Bends
- High Strength Ductile Iron Channel
- ABS Heat Resistant Outlet Fittings
- Wide Range of Beneath Deck Pipes
- Pipe Hangers and Fixings Complete The System

Sub Surface Drainage On Bridge Decks Is An Essential Part Of Any Design

PDS are the market leaders in the design, manufacture and supply of Combined Kerb Bridge Drainage Systems. Our Hydrodeck and Envirodeck kerb units provide effective surface water drainage and sub surface water collection to the asphalt layers.

Lateral drainage slots in kerb systems do provide relief to the pumping action of wheel loads within the asphalt construction, but all kerb systems are limited in their ability to drain at deck level. This is due to a base thickness of the unit and the mortar bed which can raise the sub surface collection holes further from the deck.

Kerb units are usually laid directly on top of the RSA protection or regulating course. This raises the sub surface slots on the deck units a further 20mm (approx) from the deck.

A secondary system is therefore desirable to pick up any sub surface water at this lower level.

PDS, in partnership with USL have developed a complete system for the collection of sub surface water at deck level.

PDS have become sole distributor for the Dri-deck sub surface drainage system. In addition we have developed a separate channel drainage solution to provide continuous water collection at deck level.

The channels and components have been designed to be fully compatible and complement the existing Dri-deck range of products.

PDS can also offer advice, designs and supply on carrier pipes beneath the deck in a wide range of materials including UPVC, Polyethylene and Cast Ductile Iron. The whole system is completed by a full range of pipe hangers and supports, including Expansion Joint bellows where carrier pipes have to cross Expansion points.

Introduction

The Dri-deck drainage unit provides sub surface collection at two levels.

Water is collected immediately above the waterproofing membrane and also from any bituminous protection such as Red Sand Asphalt or regulating course.

The Dri-Deck channel provides continuous sub surface water collection along kerb lines and/or can be placed transversely along the deck.

T pieces, bends and cross sections allow a number of drainage designs.

The channel sections can be situated close to the Dri-deck unit as a soakaway type of outlet (fig 3) or channel

outlets (DDCO) can be placed directly over the Dri-deck base section Fig 2 (06101)

The System

The Dri-deck Channel is Shown in Fig 1

Dri-deck channel units 1mtr in length have a number of slots along the length for high water collection. Manufactured in spheroidal graphite iron they are extremely robust and able to withstand the point loadings placed by tarmac rollers.

They are also highly resistant to road salts. The channels are bonded to the waterproofing using Dri-deck bedding compound. Tee Sections, Bends, Cross pieces and Outlets complete the system.

Fig 1



DDC

1mtr Linear Section

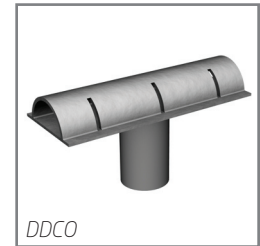

DDCO

Outlet Section

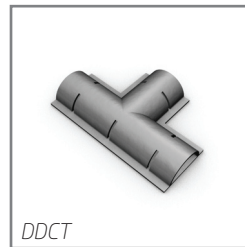

DDCT

Tee Section



DDCB90

90 Degree Angle



DDCB45

45 Degree Angle



DDCX

Cross Section

Angled Tees and Cross pieces allow numerous channel designs to optimise subsurface water collection.

Access to the system for cleaning / maintenance can be achieved by strategic placement of the kerblines rodding access unit. Ref DDRA



HB or 45 Splay

Rodding Access Unit
Height Adjustable

Expansion Joint Units also available

The Dri-deck Unit is shown in Fig 2

The base (D6101) unit is recessed to provide a seating for the cover unit and incorporates a flared edge for a smooth transition and termination of the waterproofing membrane.

The unique convoluted cover units are formed from a high strength and resilient thermoplastic material which is heat resistant and proven to resist deformation under surfacing compaction. Inlet holes at the top and bottom of the cover unit allow drainage from above and below the waterproofing protective layer.

The system is supplied with a range of compatible pipework which makes both economic and easy to use.

The 57mm High standard cover unit is suitable for a minimum surfacing depth of 75mm. A special 42mm low profile cover unit is available for shallower depths. All other components are listed.

Installation of the Dri-deck System

Dri-deck Outlets

The base unit is cast in-situ during the deck concreting operation for new works construction or alternatively is set into a core-drilled recess in the deck during refurbishment or maintenance work.

The waterproofing membrane is then laid and lapped over the flared edge of the base unit. A temporary blanking plug is placed into the base unit, allowing unimpeded machine laying of the protective layer.

Finally the plug is removed and the cover unit located prior to completion of the surfacing. For detailed information, please refer to Components Specification section.

Dri-deck Channels

These should be located along kerb lines and/or transversely across the deck close to any expansion joints and bonded directly onto the waterproofing using Dri-deck Fixing Compound.

Care should be taken with the bedding material so no voids exist between the channel flange and the deck. Any outlets and fittings are fixed into position and the RSA or regulating course is then laid.

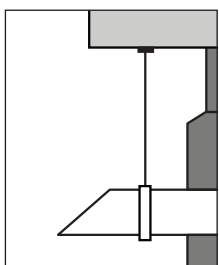

Hangers & Fixings

DDPH - Pipe hangers & fixings are available in a wide range of sizes and material finish.

COMPONENT SPECIFICATION

Fig 2

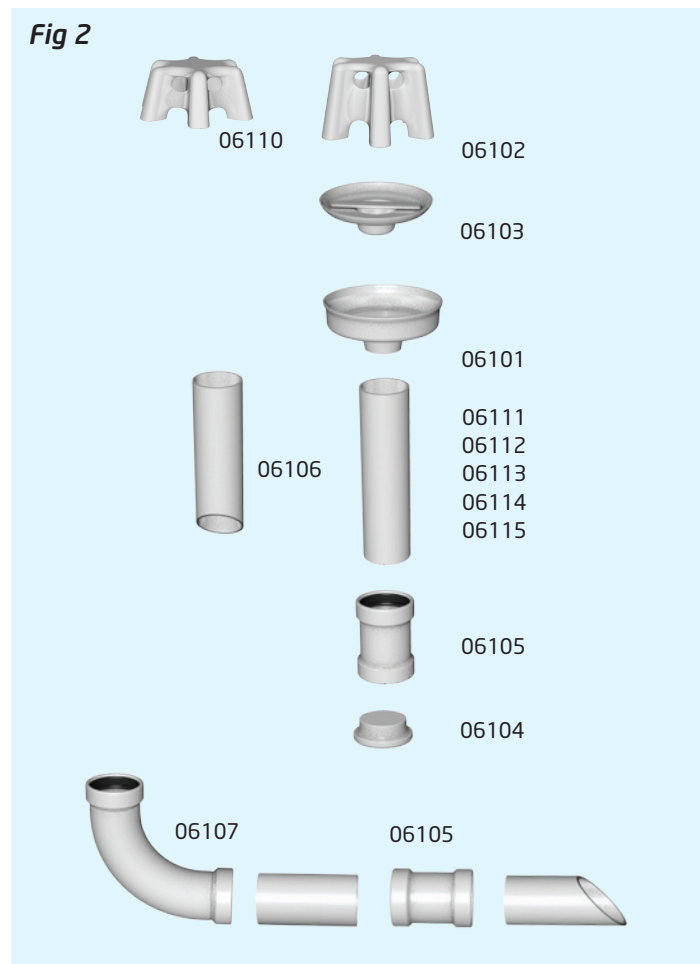

Stock No	Description	Stock No	Description
06101	Base Units	06108	45° Bend
06102	Cover Unit (Standard Profile)	06110	Cover Unit (Low Profile)
06103	Blanking Plug	06111	1m Polyethylene Pipe
06104	Soffit Unit	06112	2m Polyethylene Pipe
06105	Pipe Connector	06113	3m Polyethylene Pipe
06106	Drip Pipe	06114	4m Polyethylene Pipe
06107	Slow Bend (87.5°, 32.5°)	06115	1.33m Polyethylene Pipe

Fig 3

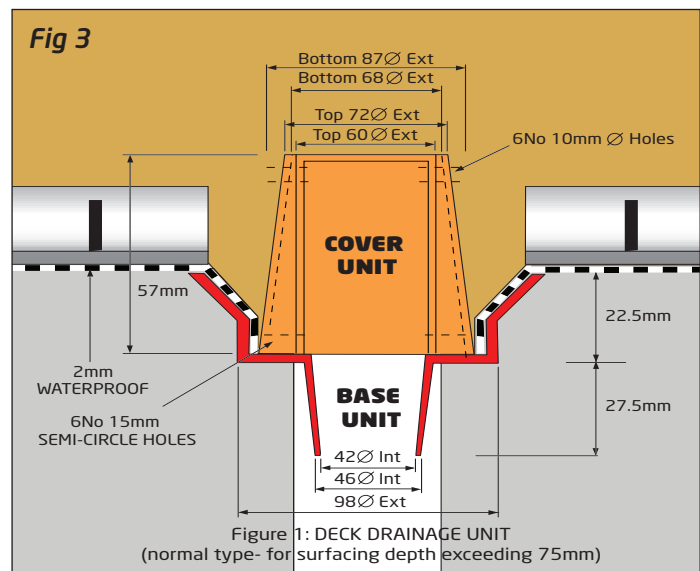

Dri-deck Outlets Installation Detail

New Works

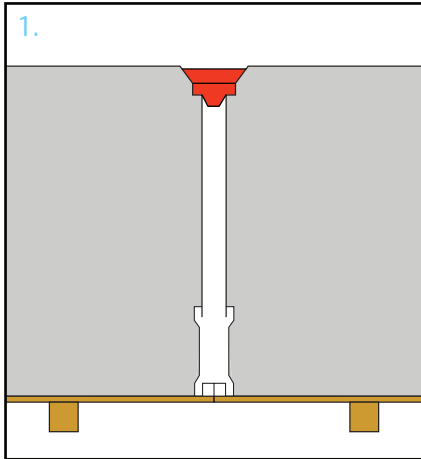

1. Nail the soffit unit at the required drain position. Place the pipe connector over the soffit unit and set the base unit to the required deck level.
2. Close off the pipework using the blanking plug or by another suitable means before concreting the deck.
3. Remove plug immediately after concreting, clean and replace to prevent debris and detritus from blocking the outfall.
4. Refer to steps 4 -7 in the refurbishment section.

Refurbishment Scheme

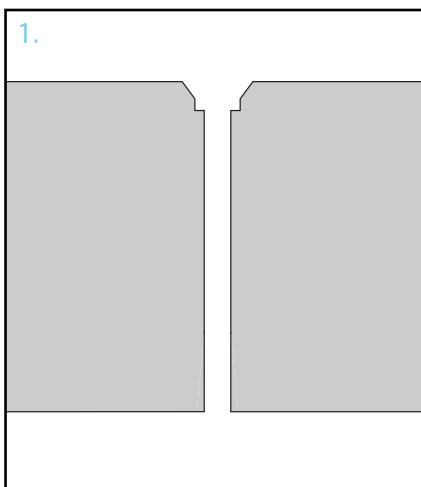

Core drill at selected positions a hole of 60mm minimum diameter through the deck.
Concentrically drill a larger hole of 140mm min. Dia. to a depth of 30mm min.

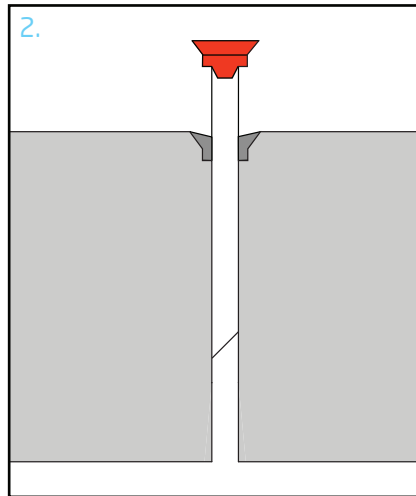

Assemble the base unit onto selected outfall pipe. Ensuring recess is clean and dry set the drainage components into position with suitable repair mortar, trowelling flush with the deck and allow to cure.

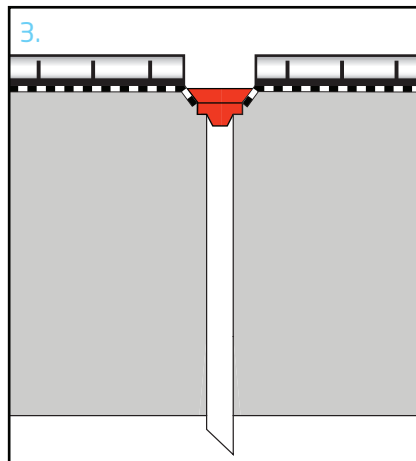

Ensuring the base unit is clean and dry, lay the waterproof membrane. Dri-deck channels are then fixed in accordance with the design layout.

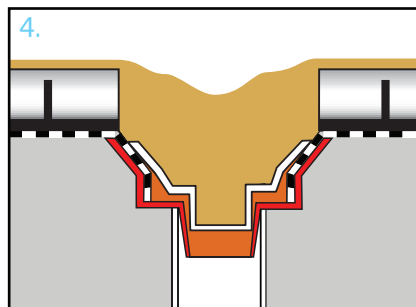

Insert the blanking plug unit and lay the sand asphalt or regulating course as specified. Whilst the surfacing is still warm, carefully remove the plug and the collected surfacing.

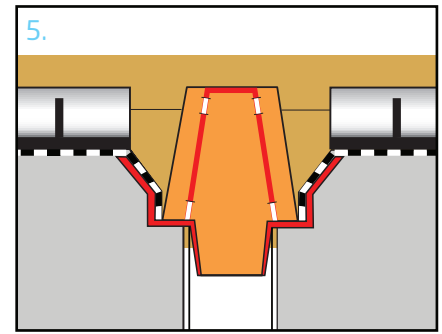

Insert the cover unit immediately prior to laying the base course material. Hand lay and bed in the cover unit in base course material prior to laying the actual base course.

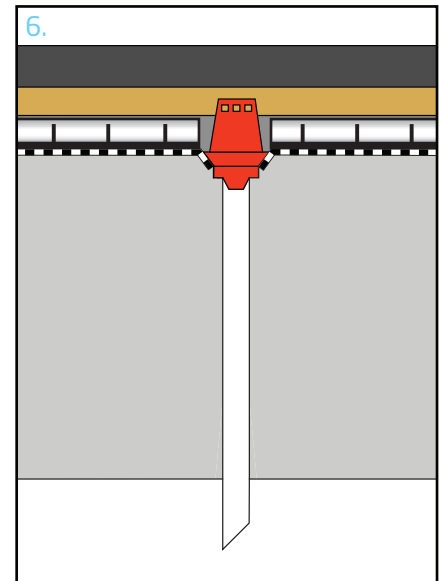

Complete the surfacing.

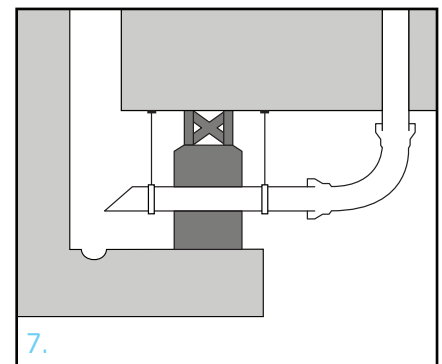

The outfall may be collected and discharged positively into a suitable storm water system, or into the drainage pipework from the Envirodeck/ Hydrodeck combined kerb drainage system.

Sales & Distribution Centre

12a Flanshaw Way, Flanshaw
Wakefield WF29LP, UK
Tel: +44 (0) 8707 541 200
Fax: +44 (0) 8707 541 201
✉ sales@pds-plc.com
🌐 www.pds-plc.com



PIPELINE & DRAINAGE SYSTEMS PLC
DEVELOPING PIPELINE & DRAINAGE SOLUTIONS