

# Max-E-Channel

|                  |    |
|------------------|----|
| Components       | 63 |
| Hydraulic Data   | 65 |
| Standard Details | 68 |
| Construction     | 74 |
| Specification    | 73 |
| Component Codes  | 67 |

# Max-E-Channel

## Slot Drainage System

- Max-E-Channel utilises the same base units as the Beany Block system combining with Max-E-Channel top units to form a linear drainage system which is laid level with the pavement surface. This high flow capacity system offers the choice of top units of various materials and load classifications.
- Max-E-Channel top units come in the following materials:
  - Hydraulically pressed concrete
  - Hydraulically pressed reinforced concrete
  - Fabricated galvanised steel
  - Cast iron
- The appropriate top unit is then bedded onto any of the 4 Beany base units being 205mm, 295mm, 365mm and 630mm
- This forms a robust linear drainage system suitable for draining large paved surfaces varying from pedestrian precincts to heavy duty industrial areas and highways.

### Versatile

- The various Top Units are easily interchangeable, ensuring easy transition from one type to another where performance requirements vary within the same scheme.

- As expected Max-E-Channel integrates with the Beany Block Top Units creating a unique system capable of providing continuous drainage of the carriageway at road and vehicular crossings.
- The introduction of the inlaid Top Units offers all the advantages of this high capacity system yet creates a discrete surface to be incorporated into the most aesthetic of landscape schemes.
- Concrete Top Units are available as standard in a natural pimple finish although other aesthetically pleasing units are also available.

### Load Classifications

- The Max-E-Channel System is strength tested in accordance with BS EN 1433:2002 to the following classes:

|                     |            |
|---------------------|------------|
| Concrete            | C250       |
| Reinforced Concrete | E600       |
| In-Laid Top         | up to D400 |
| Cast Iron           | F900       |

### Access Cover and Frame

A heavy duty cover frame is available for use with Outfalls and Silt Traps to allow for inspection and maintenance.

Max-E-Channel is a high capacity system able to store storm water. Where limitations are placed on outfall capacities, Max-E-Channel can help eliminate the need for storage reservoirs or balancing ponds

Max-E-Channel System is proven on all types of highway and hard landscape areas

The high inherent strength and durability of the system can:

- Allow complete compaction of surfacing materials adjacent to the channel during construction
- Withstand de-icing salts and freeze/thaw effects reducing maintenance and increasing service life

As Max-E-Channel is compatible with Beany Block, it can be used where continuous drainage of the carriageway is required at vehicular or road crossings

Range of Top Units can be selected in all loading classes, this enables specifier/contractor to use Max-E-Channel in any given scenario

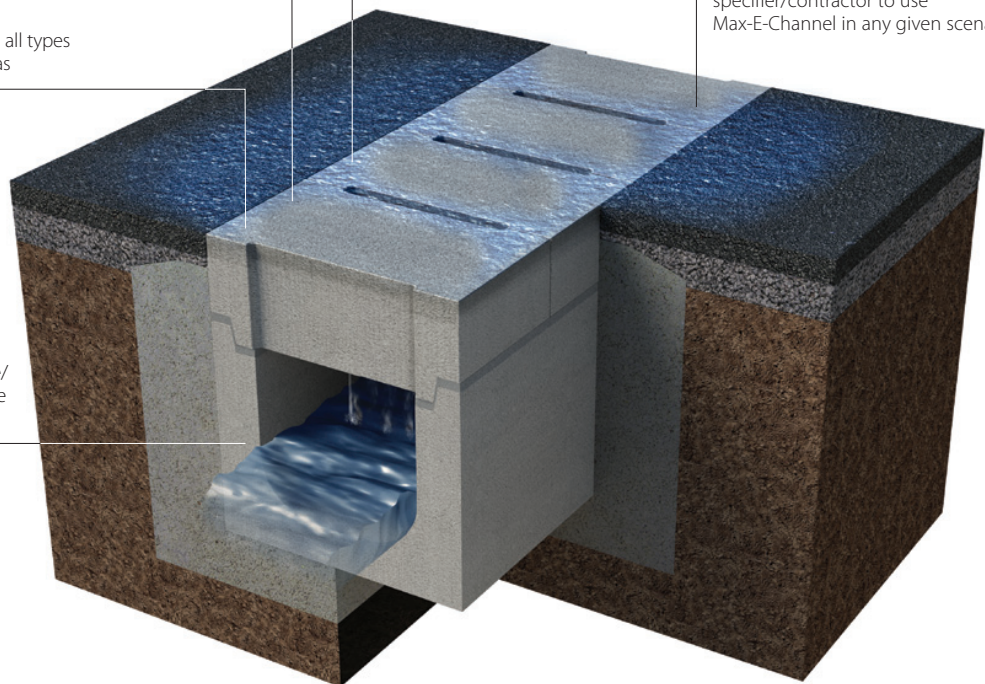

# Special Finishes

## **Conservation Max-E-Channel**

A silver-grey coarse textured finish top unit, manufactured with granite aggregate, complements perfectly areas of high architectural, historical and scenic value. This product complements Marshalls Silver Grey Conservation Paving Kerb and Edging along with Mistral Concrete Block Paving and Conservation Setts.

## **Textured Max-E-Channel**

An exposed aggregate textured finish on the visible faces of the top units is available providing high aesthetic qualities where the granite aggregate finish is not required.



Textured Top Units, Cambourne, South Cambridge

# Components

## TOP COMPONENTS

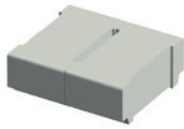

### Concrete C250

- 250mm long hydraulically pressed concrete.
- Standard natural pimple faced concrete.
- Load Classification C250.

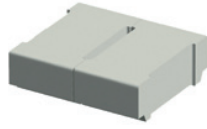

### Reinforced Concrete E600

- 250mm long hydraulically pressed reinforced concrete.
- Standard natural pimple faced concrete.
- Load classification E600.

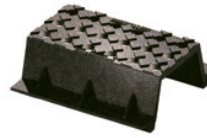

### Cast Iron F900

- 500mm long cast iron units.
- Ideal for locations subject to fast moving traffic.
- Load classification F900.

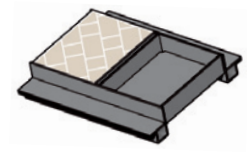

### In-Laid Unit

- 500mm long galvanised steel frame for paving inset.
- Provides unobtrusive high capacity system.
- Allows paving to continue over drainage system.
- Load Classification D400.
- Bespoke to project requirement.

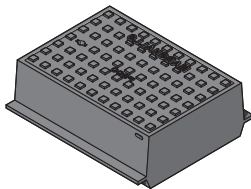

### Max-E-Channel Access Cover

- Cast Iron Access Covers and Frames are available for use at outfalls, silt traps and access points.
- A full depth unit compatible with all top units.
- End hinged for ease of access and security.
- Large access opening for the easy emptying of silt traps and outfall sumps.

- Refer to Marshalls Drainage Design Guide for design advice and detailing.
- Load classification F900.

## BASE COMPONENTS

All Base Units, Ancillary Items and Transition Units are 500mm long

### BASE UNITS

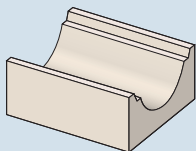

205 Base

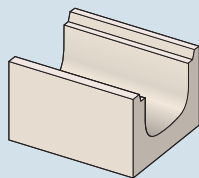

295 Base

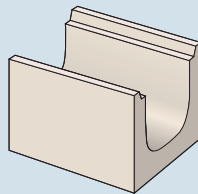

365 Base

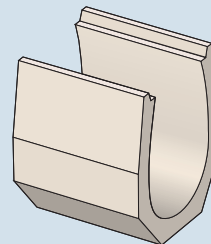

630 Base

### TRANSITION UNITS

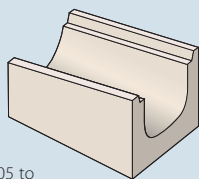

205 to  
295 Transition

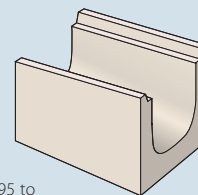

295 to  
365 Transition

### ANCILLARY ITEMS

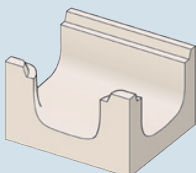

Junction  
For base 205 & 295

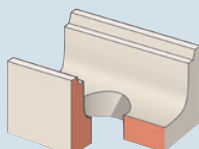

Outfall (shown sectioned for  
illustrative purposes)  
For bases 205, 295 and 365

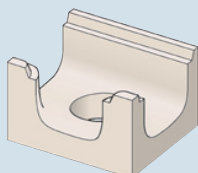

Junction/Outfall  
For bases 205 and 295

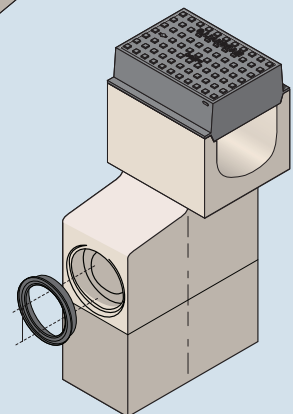

Gully Outfall

A trapped outfall is available to suit either 150mm or 225mm diameter outfall pipe.

**Note: Gully Outfall does not include base outfall or access cover and frame.**

### BASE END CAPS

Base End Caps are available for 205, 295 and 365 base units. The galvanised steel plates act as permanent formwork to a concrete surround. This is an optional detail to the use of engineering bricks, see the Drainage Design Guide.

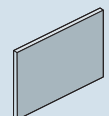

## FLOW CAPACITY (litres/sec)

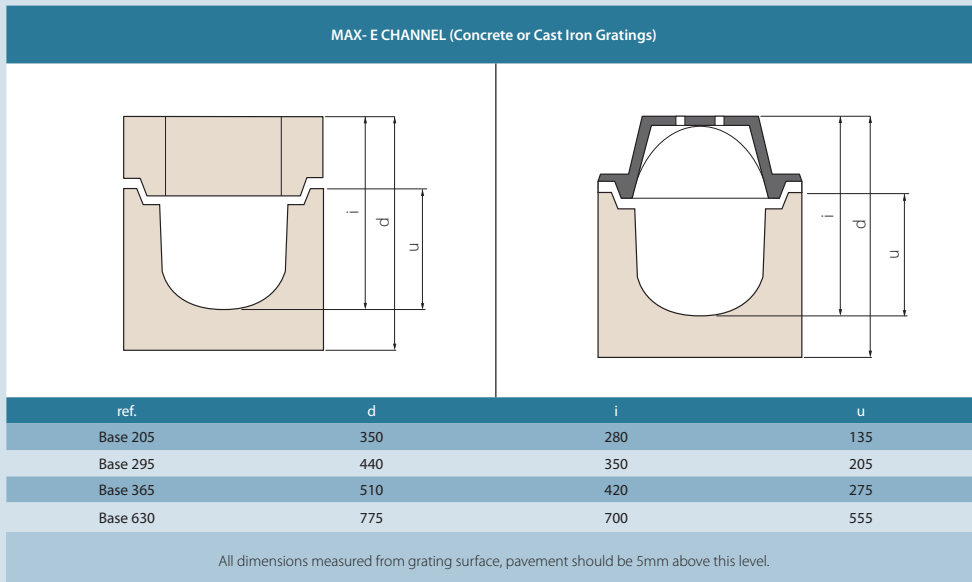
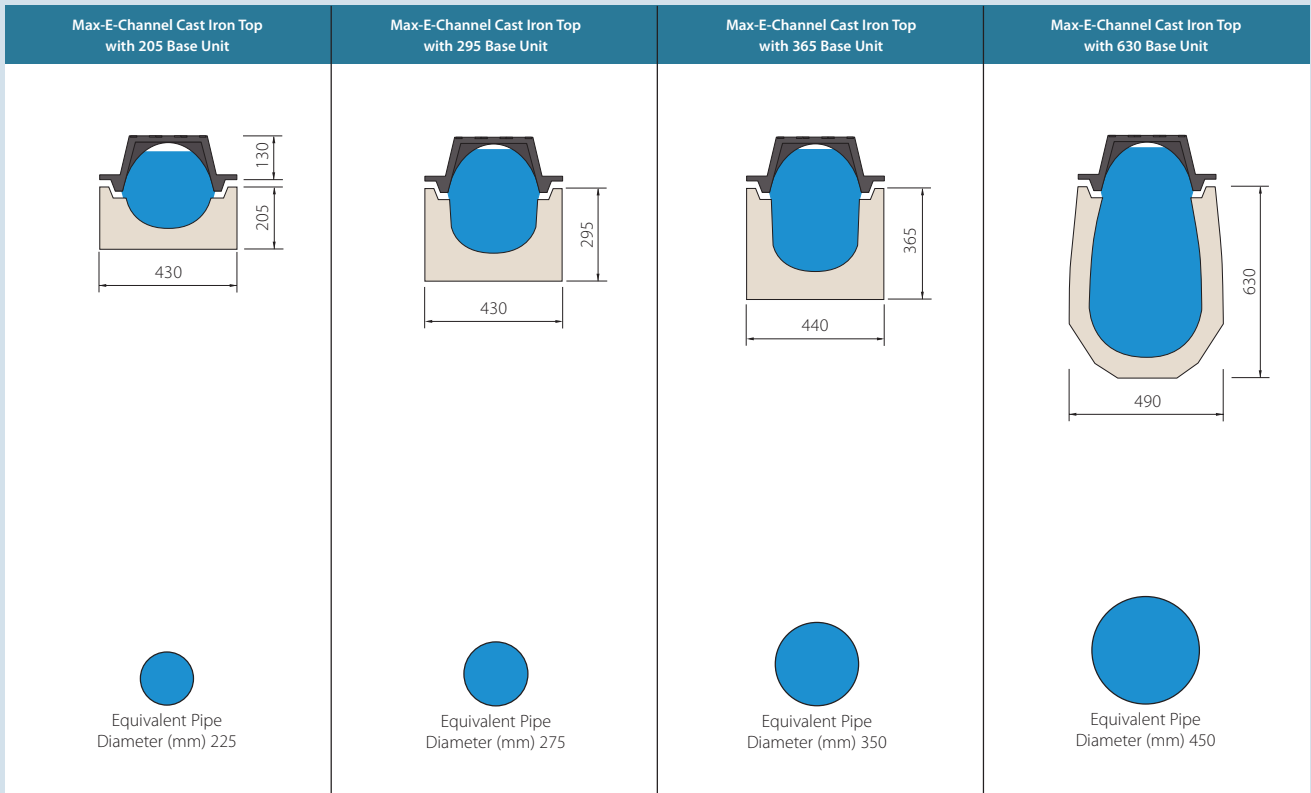

# Hydraulic Data

The Max-E-Channel hydraulic data stated in the following tables comprises of flow capacity, in litres per second (l/s) and velocity in metres per second (m/s). This data has been calculated using spatially variable flow design principles.

## Max-E-Channel With Cast Iron Top Units

| Base 205   |      |      |           |      |          |      |          |      |          |      |          |      |          |      |         |      |
|------------|------|------|-----------|------|----------|------|----------|------|----------|------|----------|------|----------|------|---------|------|
| Gradient   | Zero |      | 1 in 1000 |      | 1 in 500 |      | 1 in 400 |      | 1 in 300 |      | 1 in 200 |      | 1 in 100 |      | 1 in 50 |      |
| Length (m) | l/s  | m/s  | l/s       | m/s  | l/s      | m/s  | l/s      | m/s  | l/s      | m/s  | l/s      | m/s  | l/s      | m/s  | l/s     | m/s  |
| 25         | 18   | 0.45 | 21        | 0.53 | 23       | 0.58 | 24       | 0.60 | 26       | 0.65 | 29       | 0.73 | 34       | 0.85 | 42      | 1.05 |
| 50         | 17   | 0.43 | 21        | 0.53 | 24       | 0.60 | 25       | 0.63 | 27       | 0.68 | 32       | 0.80 | 37       | 0.93 | 45      | 1.13 |
| 75         | 15   | 0.38 | 20        | 0.50 | 24       | 0.60 | 26       | 0.65 | 29       | 0.73 | 34       | 0.85 | 39       | 0.98 | 47      | 1.18 |
| 100        | 14   | 0.35 | 20        | 0.50 | 24       | 0.60 | 26       | 0.65 | 30       | 0.75 | 37       | 0.93 | 42       | 1.05 | 50      | 1.25 |
| 125        | 13   | 0.33 | 19        | 0.48 | 24       | 0.60 | 27       | 0.68 | 31       | 0.78 | 39       | 0.98 | 44       | 1.10 | 52      | 1.30 |
| 150        | 12   | 0.30 | 19        | 0.48 | 25       | 0.63 | 28       | 0.70 | 32       | 0.80 | 42       | 1.05 | 47       | 1.18 | 55      | 1.38 |
| 175        | 10   | 0.25 | 18        | 0.45 | 25       | 0.63 | 28       | 0.70 | 33       | 0.83 | 44       | 1.10 | 49       | 1.23 | 57      | 1.43 |
| 200        | 9    | 0.23 | 18        | 0.45 | 25       | 0.63 | 29       | 0.73 | 35       | 0.85 | 47       | 1.18 | 52       | 1.30 | 60      | 1.50 |

| Base 295   |      |      |           |      |          |      |          |      |          |      |          |      |          |      |         |      |
|------------|------|------|-----------|------|----------|------|----------|------|----------|------|----------|------|----------|------|---------|------|
| Gradient   | Zero |      | 1 in 1000 |      | 1 in 500 |      | 1 in 400 |      | 1 in 300 |      | 1 in 200 |      | 1 in 100 |      | 1 in 50 |      |
| Length (m) | l/s  | m/s  | l/s       | m/s  | l/s      | m/s  | l/s      | m/s  | l/s      | m/s  | l/s      | m/s  | l/s      | m/s  | l/s     | m/s  |
| 25         | 32   | 0.50 | 38        | 0.59 | 42       | 0.66 | 44       | 0.69 | 46       | 0.72 | 52       | 0.81 | 61       | 0.95 | 75      | 1.17 |
| 50         | 31   | 0.48 | 37        | 0.58 | 42       | 0.66 | 45       | 0.70 | 48       | 0.75 | 55       | 0.86 | 64       | 1.00 | 78      | 1.22 |
| 75         | 30   | 0.47 | 36        | 0.56 | 43       | 0.67 | 46       | 0.72 | 50       | 0.78 | 58       | 0.91 | 67       | 1.05 | 81      | 1.27 |
| 100        | 29   | 0.45 | 36        | 0.56 | 43       | 0.67 | 46       | 0.72 | 52       | 0.81 | 62       | 0.97 | 71       | 1.11 | 85      | 1.33 |
| 125        | 27   | 0.42 | 35        | 0.55 | 43       | 0.67 | 47       | 0.73 | 54       | 0.84 | 66       | 1.03 | 74       | 1.16 | 88      | 1.38 |
| 150        | 25   | 0.39 | 35        | 0.55 | 44       | 0.69 | 48       | 0.75 | 55       | 0.86 | 69       | 1.08 | 77       | 1.20 | 92      | 1.44 |
| 175        | 23   | 0.36 | 34        | 0.53 | 44       | 0.69 | 49       | 0.77 | 57       | 0.89 | 72       | 1.13 | 80       | 1.25 | 94      | 1.47 |
| 200        | 21   | 0.33 | 33        | 0.52 | 44       | 0.69 | 50       | 0.78 | 58       | 0.91 | 76       | 1.19 | 84       | 1.31 | 98      | 1.53 |
| 225        | 19   | 0.30 | 33        | 0.52 | 45       | 0.70 | 51       | 0.80 | 59       | 0.92 | 78       | 1.22 | 89       | 1.39 | 101     | 1.58 |
| 250        | 17   | 0.27 | 32        | 0.50 | 45       | 0.70 | 51       | 0.80 | 61       | 0.95 | 82       | 1.28 | 91       | 1.42 | 105     | 1.64 |
| 275        | 16   | 0.25 | 31        | 0.48 | 45       | 0.70 | 52       | 0.81 | 63       | 0.98 | 85       | 1.33 | 94       | 1.47 | 109     | 1.70 |

| Base 365   |      |      |           |      |          |      |          |      |          |      |          |      |          |      |         |      |
|------------|------|------|-----------|------|----------|------|----------|------|----------|------|----------|------|----------|------|---------|------|
| Gradient   | Zero |      | 1 in 1000 |      | 1 in 500 |      | 1 in 400 |      | 1 in 300 |      | 1 in 200 |      | 1 in 100 |      | 1 in 50 |      |
| Length (m) | l/s  | m/s  | l/s       | m/s  | l/s      | m/s  | l/s      | m/s  | l/s      | m/s  | l/s      | m/s  | l/s      | m/s  | l/s     | m/s  |
| 25         | 46   | 0.55 | 54        | 0.64 | 59       | 0.70 | 61       | 0.73 | 65       | 0.77 | 72       | 0.86 | 84       | 1.00 | 104     | 1.24 |
| 50         | 44   | 0.52 | 53        | 0.63 | 59       | 0.70 | 62       | 0.74 | 67       | 0.80 | 76       | 0.90 | 88       | 1.05 | 108     | 1.29 |
| 75         | 42   | 0.50 | 52        | 0.62 | 60       | 0.71 | 63       | 0.75 | 69       | 0.82 | 80       | 0.95 | 92       | 1.10 | 112     | 1.33 |
| 100        | 40   | 0.48 | 51        | 0.61 | 60       | 0.71 | 64       | 0.76 | 70       | 0.83 | 84       | 1.00 | 95       | 1.13 | 116     | 1.38 |
| 125        | 39   | 0.46 | 51        | 0.61 | 60       | 0.71 | 65       | 0.77 | 72       | 0.86 | 88       | 1.05 | 99       | 1.18 | 120     | 1.43 |
| 150        | 37   | 0.44 | 50        | 0.60 | 61       | 0.73 | 66       | 0.79 | 74       | 0.88 | 92       | 1.10 | 103      | 1.23 | 124     | 1.48 |
| 175        | 35   | 0.42 | 49        | 0.58 | 61       | 0.73 | 67       | 0.80 | 76       | 0.90 | 94       | 1.12 | 107      | 1.27 | 127     | 1.51 |
| 200        | 33   | 0.39 | 49        | 0.58 | 62       | 0.74 | 68       | 0.81 | 78       | 0.93 | 98       | 1.17 | 110      | 1.31 | 131     | 1.56 |
| 225        | 31   | 0.37 | 48        | 0.57 | 62       | 0.74 | 69       | 0.82 | 80       | 0.95 | 102      | 1.21 | 114      | 1.36 | 135     | 1.61 |
| 250        | 29   | 0.35 | 47        | 0.56 | 62       | 0.74 | 70       | 0.83 | 81       | 0.96 | 108      | 1.29 | 118      | 1.40 | 138     | 1.64 |
| 275        | 27   | 0.32 | 46        | 0.55 | 63       | 0.75 | 71       | 0.85 | 83       | 0.99 | 110      | 1.31 | 122      | 1.45 | 142     | 1.69 |
| 300        | 25   | 0.30 | 45        | 0.54 | 63       | 0.75 | 72       | 0.86 | 85       | 1.01 | 114      | 1.36 | 126      | 1.50 | 146     | 1.74 |
| 325        | 24   | 0.29 | 45        | 0.54 | 63       | 0.75 | 73       | 0.87 | 87       | 1.04 | 118      | 1.40 | 130      | 1.55 | 150     | 1.79 |

| Base 630   |      |      |           |      |          |      |          |      |          |      |          |      |          |      |         |      |
|------------|------|------|-----------|------|----------|------|----------|------|----------|------|----------|------|----------|------|---------|------|
| Gradient   | Zero |      | 1 in 1000 |      | 1 in 500 |      | 1 in 400 |      | 1 in 300 |      | 1 in 200 |      | 1 in 100 |      | 1 in 50 |      |
| Length (m) | l/s  | m/s  | l/s       | m/s  | l/s      | m/s  | l/s      | m/s  | l/s      | m/s  | l/s      | m/s  | l/s      | m/s  | l/s     | m/s  |
| 50         | 122  | 0.67 | 142       | 0.78 | 156      | 0.85 | 162      | 0.89 | 172      | 0.94 | 191      | 1.04 | 224      | 1.22 | 277     | 1.51 |
| 100        | 116  | 0.63 | 140       | 0.77 | 157      | 0.86 | 165      | 0.90 | 177      | 0.97 | 202      | 1.10 | 235      | 1.28 | 288     | 1.57 |
| 150        | 110  | 0.60 | 138       | 0.75 | 158      | 0.86 | 168      | 0.92 | 182      | 0.99 | 213      | 1.16 | 246      | 1.34 | 299     | 1.63 |
| 200        | 105  | 0.57 | 136       | 0.74 | 159      | 0.87 | 171      | 0.93 | 188      | 1.03 | 224      | 1.22 | 257      | 1.40 | 310     | 1.69 |
| 250        | 100  | 0.55 | 133       | 0.73 | 160      | 0.87 | 173      | 0.95 | 194      | 1.06 | 234      | 1.28 | 267      | 1.46 | 321     | 1.75 |
| 300        | 95   | 0.52 | 130       | 0.71 | 162      | 0.89 | 176      | 0.96 | 199      | 1.09 | 245      | 1.34 | 278      | 1.52 | 332     | 1.81 |
| 350        | 90   | 0.49 | 128       | 0.70 | 163      | 0.89 | 179      | 0.98 | 205      | 1.12 | 256      | 1.40 | 289      | 1.58 | 343     | 1.87 |
| 400        | 84   | 0.46 | 127       | 0.69 | 164      | 0.90 | 182      | 0.99 | 210      | 1.15 | 267      | 1.46 | 300      | 1.64 | 354     | 1.93 |
| 450        | 78   | 0.43 | 125       | 0.68 | 165      | 0.90 | 184      | 1.01 | 215      | 1.17 | 278      | 1.52 | 311      | 1.70 | 365     | 1.99 |
| 500        | 72   | 0.39 | 123       | 0.67 | 166      | 0.91 | 187      | 1.02 | 220      | 1.20 | 289      | 1.58 | 322      | 1.76 | 376     | 2.05 |
| 550        | 67   | 0.37 | 120       | 0.66 | 167      | 0.91 | 190      | 1.04 | 226      | 1.24 | 300      | 1.64 | 333      | 1.82 | 387     | 2.11 |
| 600        | 62   | 0.34 | 118       | 0.64 | 168      | 0.92 | 193      | 1.05 | 231      | 1.26 | 311      | 1.70 | 344      | 1.88 | 397     | 2.17 |

# Hydraulic Data

## Max-E-Channel With Concrete Top Units

| Base 205 |            |      |           |      |          |      |          |      |          |      |          |      |          |      |         |      |
|----------|------------|------|-----------|------|----------|------|----------|------|----------|------|----------|------|----------|------|---------|------|
| Gradient | Zero       |      | 1 in 1000 |      | 1 in 500 |      | 1 in 400 |      | 1 in 300 |      | 1 in 200 |      | 1 in 100 |      | 1 in 50 |      |
|          | Length (m) | l/s  | m/s       | l/s  | m/s      | l/s  | m/s      | l/s  | m/s      | l/s  | m/s      | l/s  | m/s      | l/s  | m/s     |      |
| 25       | 9          | 0.38 | 11        | 0.46 | 12       | 0.50 | 13       | 0.54 | 14       | 0.58 | 17       | 0.71 | 19       | 0.79 | 24      | 1.00 |
| 50       | 7          | 0.29 | 10        | 0.42 | 13       | 0.54 | 14       | 0.58 | 16       | 0.67 | 19       | 0.79 | 22       | 0.92 | 26      | 1.08 |
| 75       | 6          | 0.25 | 10        | 0.42 | 13       | 0.54 | 14       | 0.58 | 17       | 0.71 | 22       | 0.92 | 24       | 1.00 | 29      | 1.21 |
| 100      | 5          | 0.21 | 9         | 0.38 | 13       | 0.54 | 15       | 0.63 | 18       | 0.75 | 24       | 1.00 | 27       | 1.13 | 31      | 1.29 |

| Base 295 |            |      |           |      |          |      |          |      |          |      |          |      |          |      |         |      |
|----------|------------|------|-----------|------|----------|------|----------|------|----------|------|----------|------|----------|------|---------|------|
| Gradient | Zero       |      | 1 in 1000 |      | 1 in 500 |      | 1 in 400 |      | 1 in 300 |      | 1 in 200 |      | 1 in 100 |      | 1 in 50 |      |
|          | Length (m) | l/s  | m/s       | l/s  | m/s      | l/s  | m/s      | l/s  | m/s      | l/s  | m/s      | l/s  | m/s      | l/s  | m/s     |      |
| 25       | 22         | 0.46 | 26        | 0.54 | 29       | 0.60 | 31       | 0.65 | 33       | 0.69 | 37       | 0.77 | 44       | 0.92 | 54      | 1.13 |
| 50       | 20         | 0.42 | 26        | 0.54 | 30       | 0.63 | 32       | 0.67 | 35       | 0.73 | 41       | 0.85 | 47       | 0.98 | 57      | 1.19 |
| 75       | 18         | 0.38 | 25        | 0.52 | 30       | 0.63 | 33       | 0.69 | 37       | 0.77 | 45       | 0.94 | 51       | 1.06 | 61      | 1.27 |
| 100      | 17         | 0.35 | 24        | 0.50 | 31       | 0.65 | 34       | 0.71 | 38       | 0.79 | 48       | 1.00 | 55       | 1.15 | 65      | 1.35 |
| 125      | 15         | 0.31 | 23        | 0.48 | 31       | 0.65 | 35       | 0.73 | 40       | 0.83 | 52       | 1.08 | 58       | 1.21 | 68      | 1.42 |
| 150      | 13         | 0.27 | 23        | 0.48 | 31       | 0.65 | 35       | 0.73 | 42       | 0.88 | 56       | 1.17 | 62       | 1.29 | 72      | 1.50 |
| 175      | 11         | 0.23 | 22        | 0.46 | 32       | 0.67 | 36       | 0.75 | 44       | 0.92 | 59       | 1.23 | 66       | 1.38 | 76      | 1.58 |

| Base 365 |            |      |           |      |          |      |          |      |          |      |          |      |          |      |         |      |
|----------|------------|------|-----------|------|----------|------|----------|------|----------|------|----------|------|----------|------|---------|------|
| Gradient | Zero       |      | 1 in 1000 |      | 1 in 500 |      | 1 in 400 |      | 1 in 300 |      | 1 in 200 |      | 1 in 100 |      | 1 in 50 |      |
|          | Length (m) | l/s  | m/s       | l/s  | m/s      | l/s  | m/s      | l/s  | m/s      | l/s  | m/s      | l/s  | m/s      | l/s  | m/s     |      |
| 25       | 35         | 0.51 | 41        | 0.60 | 46       | 0.68 | 47       | 0.69 | 50       | 0.74 | 56       | 0.82 | 66       | 0.97 | 81      | 1.19 |
| 50       | 33         | 0.49 | 40        | 0.59 | 46       | 0.68 | 48       | 0.71 | 52       | 0.76 | 60       | 0.88 | 70       | 1.03 | 85      | 1.25 |
| 75       | 31         | 0.46 | 39        | 0.57 | 46       | 0.68 | 49       | 0.72 | 54       | 0.79 | 64       | 0.94 | 74       | 1.09 | 89      | 1.31 |
| 100      | 29         | 0.43 | 39        | 0.57 | 47       | 0.69 | 50       | 0.74 | 56       | 0.82 | 68       | 1.00 | 78       | 1.15 | 93      | 1.37 |
| 125      | 27         | 0.40 | 38        | 0.56 | 47       | 0.69 | 51       | 0.75 | 58       | 0.85 | 73       | 1.07 | 82       | 1.21 | 98      | 1.44 |
| 150      | 25         | 0.37 | 37        | 0.54 | 47       | 0.69 | 52       | 0.76 | 60       | 0.88 | 77       | 1.13 | 86       | 1.26 | 102     | 1.50 |
| 175      | 23         | 0.34 | 36        | 0.53 | 48       | 0.71 | 53       | 0.78 | 62       | 0.91 | 81       | 1.19 | 90       | 1.32 | 106     | 1.56 |
| 200      | 21         | 0.31 | 35        | 0.51 | 48       | 0.71 | 54       | 0.79 | 66       | 0.97 | 85       | 1.25 | 94       | 1.38 | 108     | 1.59 |
| 225      | 19         | 0.28 | 35        | 0.51 | 49       | 0.72 | 55       | 0.81 | 67       | 0.99 | 89       | 1.31 | 98       | 1.44 | 114     | 1.68 |

| Base 630 |            |      |           |      |          |      |          |      |          |      |          |      |          |      |         |      |
|----------|------------|------|-----------|------|----------|------|----------|------|----------|------|----------|------|----------|------|---------|------|
| Gradient | Zero       |      | 1 in 1000 |      | 1 in 500 |      | 1 in 400 |      | 1 in 300 |      | 1 in 200 |      | 1 in 100 |      | 1 in 50 |      |
|          | Length (m) | l/s  | m/s       | l/s  | m/s      | l/s  | m/s      | l/s  | m/s      | l/s  | m/s      | l/s  | m/s      | l/s  | m/s     |      |
| 50       | 108        | 0.65 | 126       | 0.75 | 139      | 0.83 | 145      | 0.87 | 154      | 0.92 | 172      | 1.03 | 201      | 1.20 | 249     | 1.49 |
| 100      | 102        | 0.61 | 124       | 0.74 | 141      | 0.84 | 148      | 0.89 | 160      | 0.96 | 184      | 1.10 | 213      | 1.28 | 261     | 1.56 |
| 150      | 96         | 0.57 | 123       | 0.74 | 142      | 0.85 | 151      | 0.90 | 166      | 0.99 | 195      | 1.17 | 224      | 1.34 | 272     | 1.63 |
| 200      | 90         | 0.54 | 120       | 0.72 | 143      | 0.86 | 154      | 0.92 | 171      | 1.02 | 207      | 1.24 | 236      | 1.41 | 284     | 1.70 |
| 250      | 83         | 0.50 | 117       | 0.70 | 144      | 0.86 | 157      | 0.94 | 177      | 1.06 | 218      | 1.31 | 248      | 1.49 | 295     | 1.77 |
| 300      | 79         | 0.47 | 115       | 0.69 | 145      | 0.87 | 160      | 0.96 | 183      | 1.10 | 230      | 1.38 | 259      | 1.55 | 307     | 1.84 |
| 350      | 73         | 0.44 | 113       | 0.68 | 146      | 0.87 | 163      | 0.98 | 188      | 1.13 | 241      | 1.44 | 271      | 1.62 | 318     | 1.90 |
| 400      | 67         | 0.40 | 110       | 0.66 | 148      | 0.89 | 166      | 0.99 | 194      | 1.16 | 253      | 1.52 | 282      | 1.69 | 330     | 1.98 |
| 450      | 62         | 0.37 | 108       | 0.65 | 149      | 0.89 | 168      | 1.01 | 200      | 1.20 | 265      | 1.59 | 294      | 1.76 | 341     | 2.04 |
| 500      | 56         | 0.34 | 106       | 0.63 | 150      | 0.90 | 171      | 1.02 | 205      | 1.23 | 276      | 1.65 | 305      | 1.83 | 353     | 2.11 |

| Theoretical Outfall Capacities      |                           |      |     |
|-------------------------------------|---------------------------|------|-----|
| Outfall Type                        | Outlet Pipe Diameter (mm) | m/s  | l/s |
| Max-E-Channel Outfall with Base 205 | 150                       | 3.32 | 36  |
| Max-E-Channel Outfall with Base 295 | 150                       | 3.52 | 38  |
| Max-E-Channel Outfall with Base 365 | 150                       | 3.67 | 40  |
| Max-E-Channel Outfall with Base 205 | 225                       | 3.40 | 82  |
| Max-E-Channel Outfall with Base 295 | 225                       | 3.60 | 87  |
| Max-E-Channel Outfall with Base 365 | 225                       | 3.75 | 91  |

# Component Codes

| Component Codes<br>Top Units                | Unit<br>Weight (kg) | Item<br>Code     | Pack<br>Size | Pack<br>Weight |
|---|---------------------|------------------|--------------|----------------|
| Max-E Concrete Grate 250mm                  | 40                  | <b>DR9758000</b> | 32           | 1282           |
| Max-E Con Grate Reinf 250mm                 | 36                  | <b>DR9758100</b> | 32           | 1152           |
| Max-E CI Grate 500mm                        | 62                  | <b>DR9750200</b> | 24           | 1488           |
| Max-E Chan 65mm Inlaid Top Unit             | 20                  | <b>DR9800300</b> | 1            | 20             |
| Max-E Chan Galv Inlaid Top Unit             | 25                  | <b>DR9800400</b> | 1            | 25             |
| Base Channels                               | Unit<br>Weight (kg) | Item<br>Code     | Pack<br>Size | Pack<br>Weight |
| Base 205                                    | 70                  | <b>DR7200210</b> | 24           | 1680           |
| Base 295                                    | 85                  | <b>DR7200100</b> | 18           | 1530           |
| Base 365                                    | 96                  | <b>DR7200300</b> | 18           | 1728           |
| Base 630                                    | 81.2                | <b>DR7200400</b> | 4            | 440            |
| Transition Units                            | Unit<br>Weight (kg) | Item<br>Code     | Pack<br>Size | Pack<br>Weight |
| 295/365 Taper                               | 100                 | <b>DR8700100</b> | 1            | 100            |
| 205/295 Taper                               | 87                  | <b>DR8700210</b> | 1            | 87             |
| Base Components<br>Access Covers & Outfalls | Unit<br>Weight (kg) | Item<br>Code     | Pack<br>Size | Pack<br>Weight |
| Max-E Full Depth Access<br>Cover & Frame    | 85                  | <b>DR9800150</b> | 1            | 85             |
| Max-E Inlaid Access Cover & Frame           |                     | <b>DR9800170</b> | 1            |                |
| Gully Outfall 225                           | 242                 | <b>DR4604060</b> | 1            | 242            |
| Gully Outfall 150                           | 277                 | <b>DR4604010</b> | 1            | 277            |

Items available ex-stock



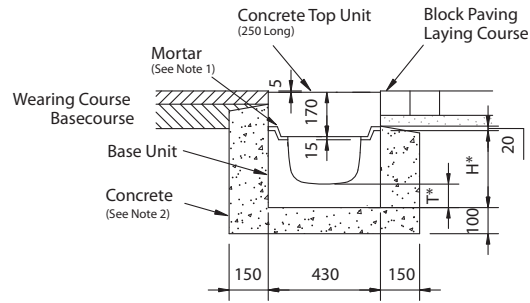

Cross Section

**Base Unit & Concrete Top Unit  
(With Flexible Or Block Paved Surfacing  
Loading C250)**

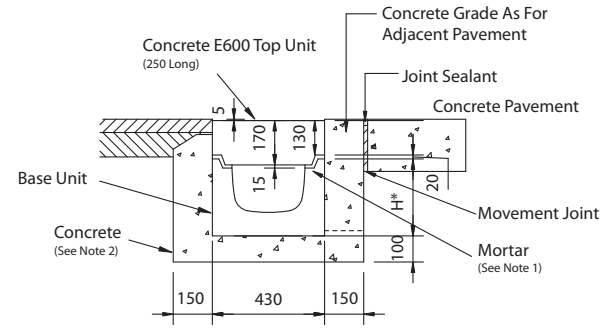

Cross Section

**Base Unit & Reinforced Concrete Top Unit  
(With Flexible Or Concrete Pavement  
Loading E600)**

\*For values of T & H,  
refer to Beany Block details.

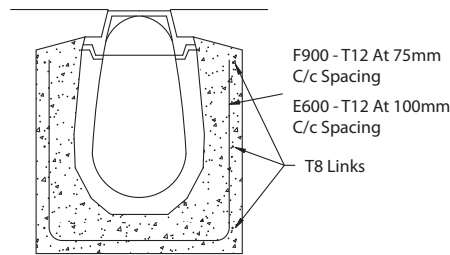

Cross Section

**E600 & F900 Applications  
For Base 630 only**

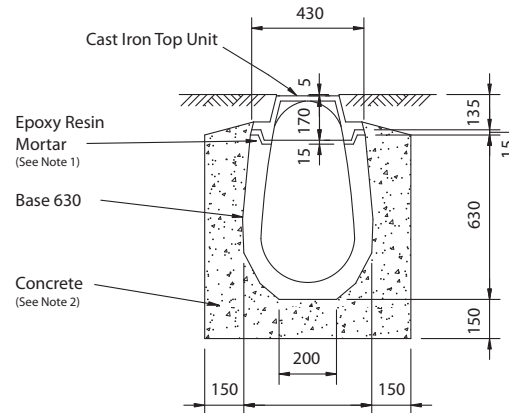

Cross Section

**Base 630 & Cast Iron  
Top Unit  
(Loading To D400)**

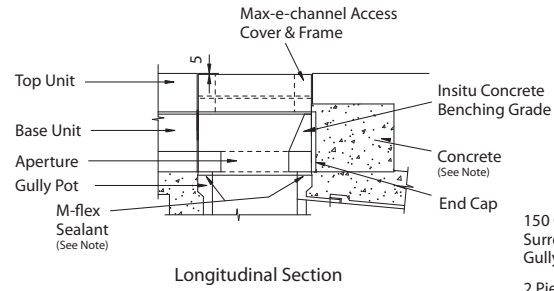
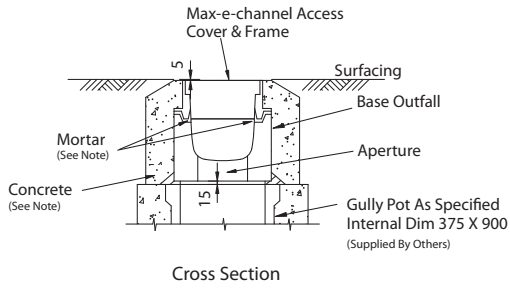

**Outfall Using Gully Pot**

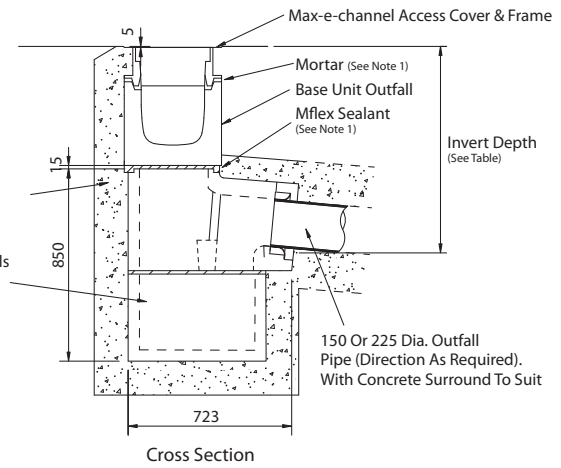
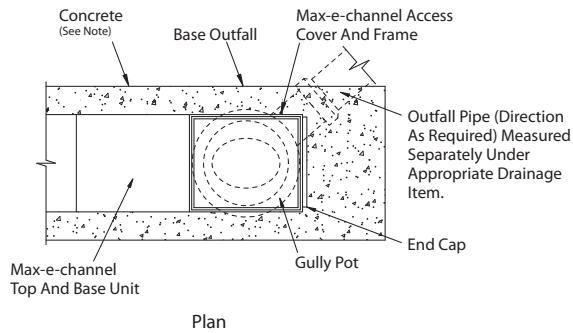

**Outfall Using Marshalls Gully Outfall**

| Outfall Pipe Invert Depth From Carriageway Level (Mm) |               |               |
|---|---------------|---------------|
| Beany Base  | 150 Ø Outfall | 225 Ø Outfall |
| 205   | 701           | 738           |
| 295   | 791           | 828           |
| 365   | 861           | 898           |

# Standard Details

Drawing 3 of 4

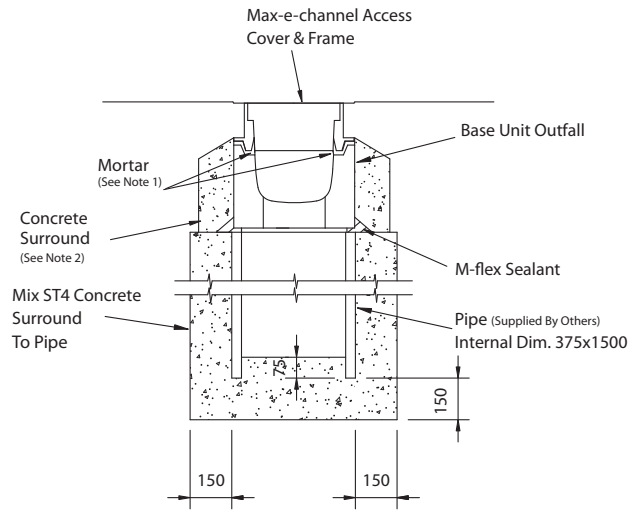

Cross Section

**Silt Trap**

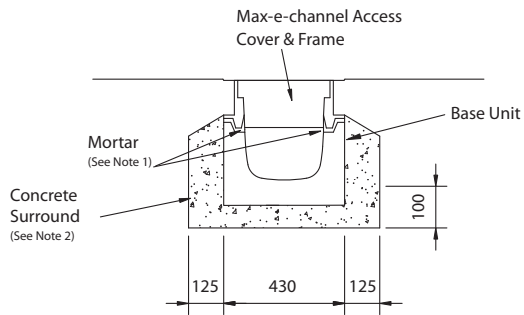

Cross Section

**Access Cover**

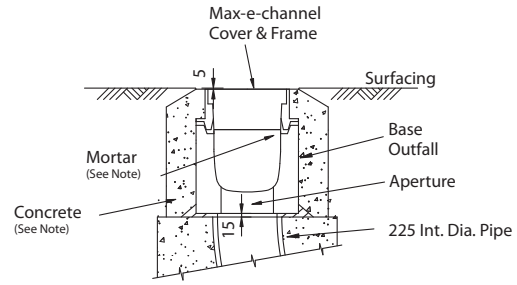

Cross Section

**Outfall Direct To 225 Dia. Pipe**

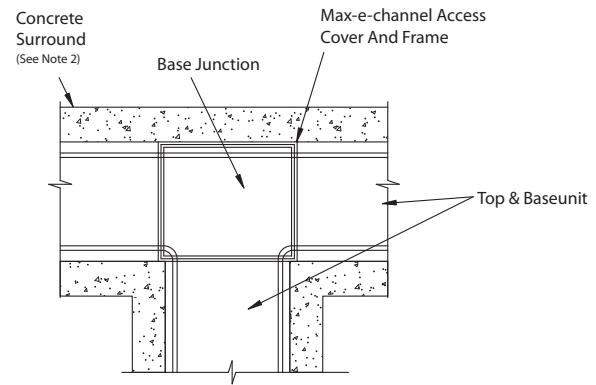

Plan

**'T' Junction**

# Standard Details

Drawing 4 of 4

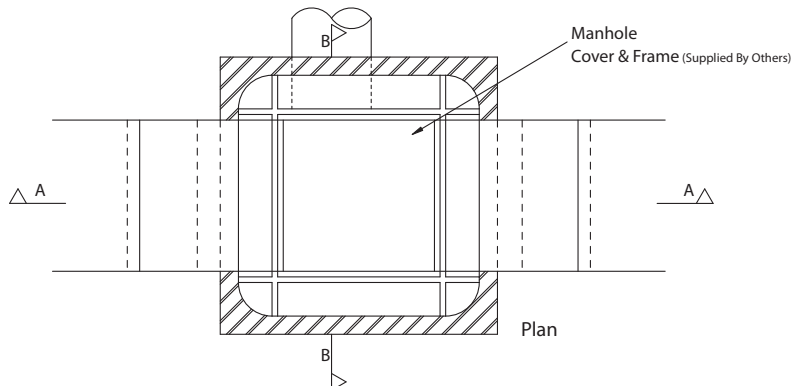
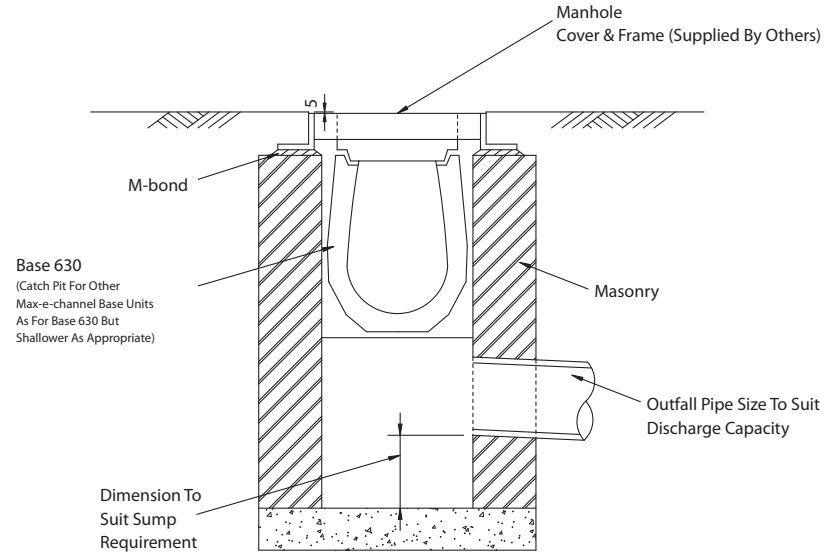
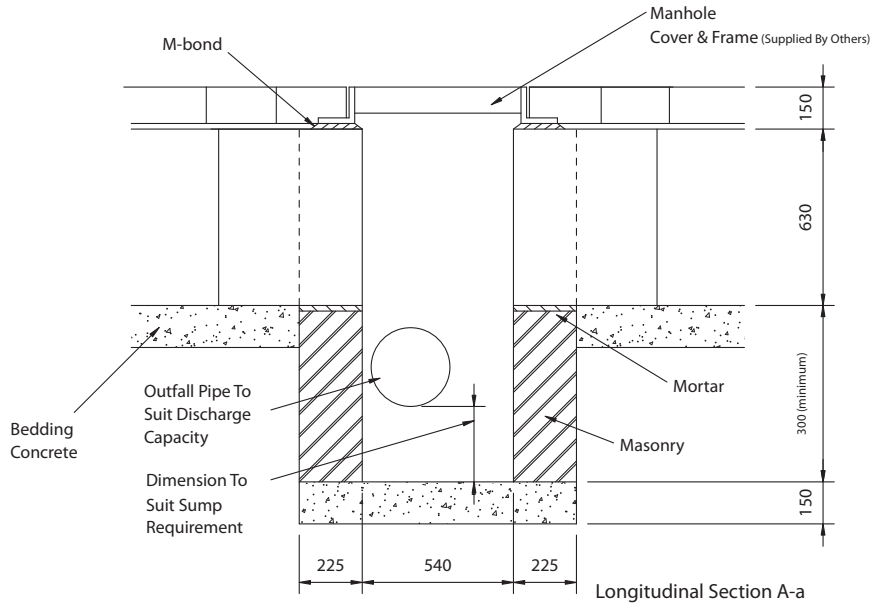

## Notes For Max-E-Channel

### Drawings 1 to 4

1. Mortars shall be;
  - i) A Mortar class 12 cement mortar to BS EN 998-2 for bedding of the Concrete Top Units for applications up to Load Classification D400 to BS EN 1433
  - ii) Marshalls' M-Bond epoxy mortar for bedding of Cast Iron Top Units and reinforced concrete Top Units for Load Classification E600 and F900
  - iii) Marshalls' M-Flex for bedding Base Block Outfalls onto the Beany Trapped Gully Unit
  - iv) Marshalls' M-Flex for bedding the sections of the Marshalls' Trapped Gully Unit sections
2. Concrete bed, haunch and surround shall be;
  - i) A C20/25 concrete to BS 8500-1&2 and BS EN 206-1 for applications up to Load Classification C250 to BS EN 1433
  - ii) A C25/30 concrete to BS 8500-1&2 and BS EN 206-1 for applications up to Load Classification F900 to BS EN 1433
  - iii) Reinforcement details for Base 630 E600 and F900 applications only are as indicated
  - iv) A mix ST4 concrete to BS 8500-1&2 and BS EN 206-1 for Beany Trapped Gully, Silt Traps, Catch Pits and outfall details
  - v) The specification for carrier pipe concrete surround is by others
3. Marshalls' vertical joint sealant, M-Seal, shall be applied to all Base Blocks.
4. For Base 630 applications, all Outfalls, Silt Traps and junctions should be formed by a brick Catch Pit structure;
  - i) The outfall pipe diameter, gradient, depth to invert, depth of trap shall be by others
  - ii) The internal dimensions of the catch pit shall be 540 wide x 1000 long for Base 630 applications
  - iii) Corbelled brickwork with a maximum of 22mm steps shall be used to support the Access Cover and Frames
5. Movement joint details that fully isolate the Max-E-Channel whilst maintaining restraint shall be provided adjacent to all concrete slabs, even when the slab is covered by other materials.
6. When used in conjunction with the Beany Block system, Max-E-Channel base units are the same as Beany Block Bases.
7. All dimensions are in millimetres.

# Specification

## Introduction

The following specification covers the complete Max-E-Channel system including ancillary fittings and is compatible with the Standard Detail sheets.

Where the Manual of Contract Documents for Highway Works is used, information for "Appendix 5/6: Linear Drainage Systems" is available on request.

## Max-E-Channel

1. The linear drainage system shall be Max-E-Channel, manufactured in pre-cast concrete, with the exception of certain fittings of cast iron or galvanised steel as supplied by Marshalls, Halifax HX5 9HT in accordance with Standard Detail Sheets.
2. The linear drainage system shall consist of a two part system consisting of top units of plain concrete/reinforced concrete/galvanised mild steel/cast iron\* together with base units that are 205/295/365/630mm\* deep. The overall width of the system is not less than 430mm.
3. All components of the Max-E-Channel system, shall comply with the British Standard BS EN1433, Load Classification as follows:
  - (i) Plain concrete top units to C250\*
  - (ii) Reinforced concrete top units to E600\*
  - (iii) Cast iron top units to F900\*
  - (iv) Inlaid steel top units to D400\*
4. The system shall have a minimum of 11,200mm<sup>2</sup>/m water inlet aperture area.
5. When installed, the minimum depth of construction above the top of the base unit to the drained area surface level shall be not less than 150mm.
6. The linear drainage system comprising straight top and base units, outfalls, silt traps, access covers, junctions, end caps and sealant shall be installed to the line and levels indicated in the contract documents and in accordance with the manufacturer's instructions and Standard Details.

Note: \* delete as required

# Construction

## Introduction

Installation of the Max-E-Channel Linear Drainage System should be carried out in accordance with the Specification and Standard Detail Sheets. The following method of installation is recommended.

## Excavation

Sufficient material should be excavated to accommodate Top and Base Units, concrete bedding and haunching, any 'soft spots' or poorly compacted formation should be made good.

## Setting Out

Setting out pins should be accurately located, with a string line level with the top front corners of the Base Units. Pins can be located to the rear of the Units to avoid having to lift the Units over the string line.

## Base Units

Starting at the Outfall, i.e. working uphill, the Units should be bedded on to a freshly mixed foundation of the appropriate grade and thickness of concrete (refer to Standard Detail Sheet).

### Concrete bed, haunch and surround shall be:

- i) A C20/25 concrete to BS 8500-1&2 and BS EN 206-1 for applications up to Load Classification C250 to BS EN 1433
- ii) A C25/30 concrete to BS 8500-1&2 and BS EN 206-1 for applications up to Load Classification F900 to BS EN 1433
- iii) Reinforcement details for Base 630 application E600 and F900 ONLY are as indicated
- iv) A mix ST4 concrete to BS 8500-1&2 and BS EN 206-1 for Max-E-Channel Trapped Gullies, Silt Traps, Catch Pits and outfall details
- v) The specification for carrier pipe concrete surround is by others

Alternatively, the Units may be bedded on to a layer of cement mortar 10-40mm thick on a previously prepared concrete foundation.

Sufficient M-Seal bituminous mastic jointing compound should be trowelled on to one or both end faces so that the joint will be well sealed when the next Unit is tamped into position. Surplus sealant shall be removed from the inner surface of the Units as work proceeds.

18 litres of M-Seal should be sufficient for the following length of Max-E-Channel:

| M-Seal Requirement |                  |
|--------------------|------------------|
| Base Type          | Coverage (m/18l) |
| 205                | 90               |
| 295                | 70               |
| 365                | 55               |
| 630                | 35               |

Where cutting is necessary, one or two Units shall be cut so that no single Unit is less than 200mm in length. All cutting and trimming of the Units shall be carried out with a concrete saw or disc cutter. Cutting of Base Junctions or Outfall Units is not recommended.

At the termination of Max-E-Channel runs not located at outfalls, the base units shall be closed using galvanised steel end caps as detailed in the Standard Detail Sheets.

## Top Units

The string line should be set to the level of the top of the units.

Again, starting at the Outfall, the Units should be set directly onto a liberal quantity of stiff, cement mortar (or M Bond epoxy mortar where specified) to completely fill the whole of the joint. Cement mortar shall be Class 12 in accordance with BS EN 998-2. These should be tamped into position

close to previously laid Units and the alignment checked. The levels should be checked using the string line and a spirit level. In addition, the general alignment should be checked from all directions as each unit is laid. Surplus mortar shall be removed from the units as work proceeds.

Top Units shall be laid with the top of the unit 5mm below the final pavement level.

The inside and outside of the joints between Base and Top Units should be pointed and cleaned out with a brush or rag as work proceeds.

## Notes:

1. In order to obtain a 'good line', it is very important to lay the Top Units on the specified thickness of compacted mortar using the string line and Base Units as a guide. Too thin a layer of mortar will not allow sufficient sideways movement of the units to achieve an acceptable alignment.
2. It is not necessary for Top and Base Unit vertical joints to line up.
3. Where Max-E-Channel is laid on or adjacent to existing or proposed concrete slabs, transverse joints shall be formed within the units and haunching adjacent to the slab joints and also longitudinal movement joints between the haunching and the slabs. Where necessary, Top Unit drainage apertures shall be protected against the ingress of material during concreting operations.
4. Outfalls, Silt Traps and Access Covers shall be constructed in accordance with the Standard Detail Sheet using the appropriate type of Base Unit. Units shall be bedded on sufficient M-Flex sealant over a gully pot, Outfall Unit or vertical pipe, to make a watertight joint. Where necessary in-situ concrete benching shall be shaped to the full depth of the Base unit. In Silt Traps, the pipe shall be bedded into mix ST4 concrete which shall be fully compacted to make a watertight seal.
5. In situ concrete haunching or surround should not be placed until the installed units have been inspected and approved by the Engineer. The haunching/surrounding should be carried out as one operation to complete lines of Top and Base Units in accordance with the Standard Detail Sheet.
6. Adjacent carriageway and/or footway construction shall not be commenced within 3 days of any jointing or haunching/surrounding concrete being placed. Base Units, Outfalls or Junctions not covered by fully bedded Top Units or covers and frames, shall be adequately supported against loadings imposed by construction traffic.
7. On completion of the works, the Max-E-Channel System shall be cleaned out by high pressure water jetting (100-150 bar at 200 l/min minimum) and left free from obstructions and all Outfalls and Silt Traps shall be emptied. Top Unit drainage apertures shall be covered by timber boards or other approved method, during jetting operations. The cleaning process shall be repeated where necessary after the completion of any remedial works.
8. Installation operations should be discontinued if weather conditions are such that the performance of the Max-E-Channel may be jeopardised.
 

Installation should not be undertaken when the temperature is below 3°C on a falling thermometer and below 1°C on a rising thermometer.
9. All necessary Personal Protective Equipment (PPE) should be worn on site, as the site rules dictate. Goggles, ear protection, dust masks and protective footwear must always be worn whenever cutting operations are undertaken.