

# Stormwater and CSO Management

Flow Control  
Stormwater Treatment  
Combined Sewer Overflow Treatment

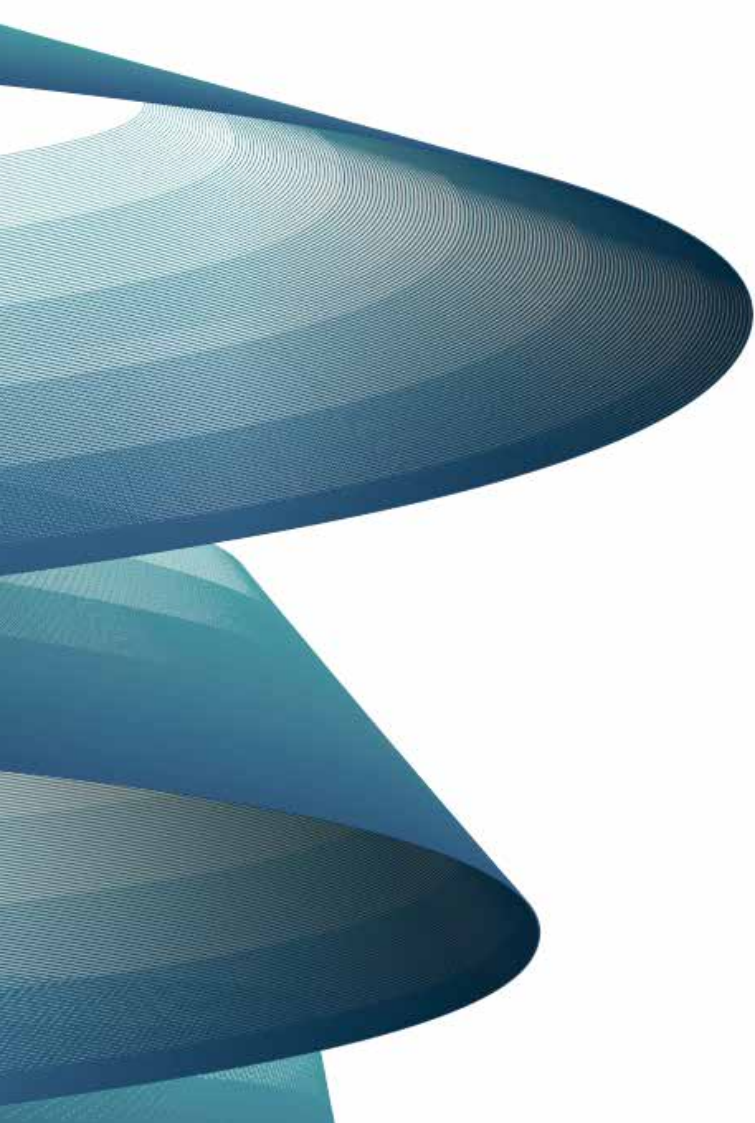

**Stormwater and CSO Solutions**  
Turning Water Around...<sup>®</sup>

# Flow Control

---

## Hydro-Brake Optimum® - There is no equivalent

The Hydro-Brake Optimum® delivers the very best in vortex flow control technology. Significant research by Hydro International's R&D team supports and validates its hydraulic performance – providing you with an unmatched solution for your flow control requirement.

As well as providing unrivalled hydraulic performance, it offers unequalled flexibility for specifiers and our 'absolute fit' promise. You may consider fitting cheaper or 'similar' solutions to Hydro-Brake Optimum®, but there really is no equivalent.



### Advantages

---

The Hydro-Brake Optimum® is our most efficient flow control to date, offering clear advantages over competitor products, including:

- A storage saving of up to 15% compared to other vortex flow control devices, cutting space requirements and reducing time and labour costs during installation.
- Outlets (clearances) up to 20% larger than competitor products, minimising the risk of blockage and future maintenance costs.
- A range of time saving installation options, including the ability to adjust flows post installation.
- Structural design and hydraulic performance independently accredited by both BBA and WRc, giving you confidence that you are fitting the best product for you job.

Accepted by water companies and local authorities across the UK and Ireland.

### Mounting Options

---

Where units are to be fitted on-site, we provide a variety of mounting options to suit the application:

- Lugs
- Push-fit spigots
- Flat or curved mounting plates
- Penstock or slide mounts
- Removable units.

All Hydro-Brake Optimum® units can also be supplied with an adjustable inlet to future-proof the device, allowing flows to be altered post-installation, to account for site expansion or climate change.



### Performance

---

The Hydro-Brake Optimum® has been assessed to the very highest level by the BBA and WRc for its hydraulic performance and ability to match even the most complicated requirements.

Demonstrating our commitment to both quality and sustainability, Hydro International is also accredited to both ISO 9001 and ISO 14001 standards.



# The Hydro StormTrain® Series

## A Comprehensive Toolbox for Surface Water Treatment

Each Hydro StormTrain® device delivers proven, measurable and repeatable surface water treatment performance. Each can be used independently to meet the specific treatment needs of a site or combined to form a management train.

Hydro StormTrain® devices can work alongside natural SuDS features to enable, protect or enhance them.

### First Defense®

Vortex Separator

The First Defense® is an economical hydrodynamic vortex separator for effective removal of coarse particles, litter and oil from surface water runoff.

Captured pollutants are kept safely within the device keeping public areas free from harmful pollutants.



Coarse particles



Gross pollutants



Liquid and sediment bound hydrocarbons

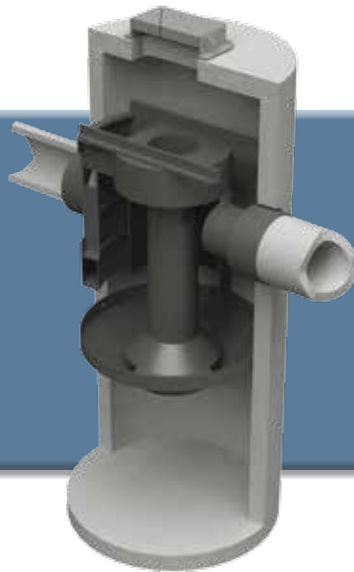
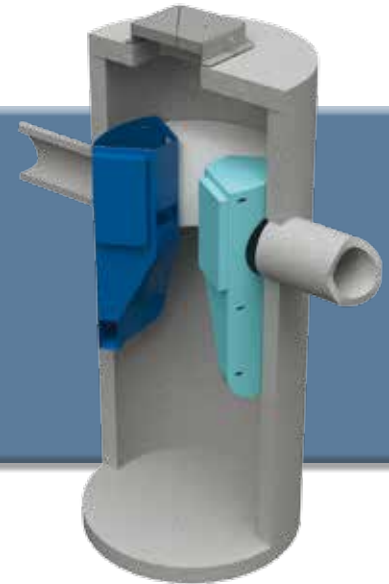

### Downstream Defender®

Advanced Hydrodynamic Vortex Separator

The Downstream Defender® is an advanced hydrodynamic vortex separator for the effective and reliable removal of fine particles along with oils and other floatable debris from surface water runoff.



Fine particles



Heavy Metals



Liquid and sediment bound hydrocarbons



Gross pollutants



Nutrients

Sediment bound

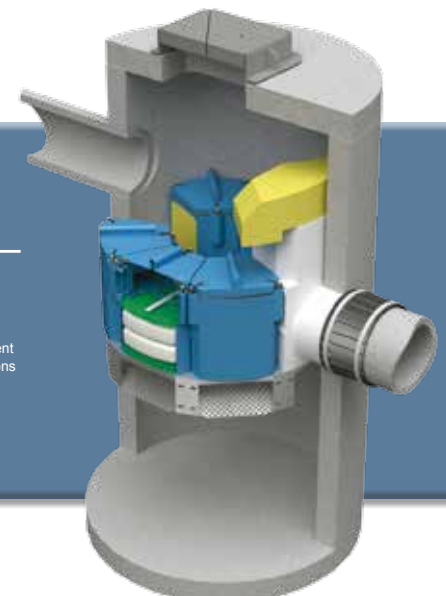

### Up-Flo™ Filter

Fluidised Bed Up Flow Filtration System

The Up-Flo™ Filter is an innovative surface water filtration technology that delivers a high-performance multi-stage treatment train within a single device. The Up-Flo™ Filter combines sedimentation and screening with fluidised bed filtration technology to deliver high levels of performance.



Very fine particles



Heavy Metals



Liquid and sediment bound hydrocarbons



Gross pollutants



Nutrients

Sediment bound

# Control of Gross Solids and Floatables from Combined Sewer

## Hydro-Static® Screen

The Hydro-Static® Screen is a non-powered screening technology suitable for sites with infrequent overflows.

A cost-effective, non-powered screen for the control of gross solids and floatables in combined sewer systems.

The Hydro-Static® Screen provides screening better than 6 mm in two directions intercepting and retaining floatables, aesthetically offensive material and gross solids over a wide range of flows. The collected material is then returned to the combined sewer after the storm event. An emergency overflow weir is incorporated into the screen should the peak design flow be exceeded.

The Hydro-Static® Screen is available as either an Up Flow Screen or a weir-mounted Through Flow Screen.



### Applications

- CSO sites with infrequent spills.
- New and retrofit CSO facilities.
- Storm tank and pumping station overflows.

## Hydro-Jet® Screen

A compact device with high hydraulic throughput, the Hydro-Jet® Screen is perfectly suited for small to medium size CSO sites.

The Hydro-Jet® Screen is an advanced, self-cleansing, non-powered screening system for the removal of material greater than 6 mm in two directions.

The Hydro-Jet® Screen is both innovative and unique. It has no power requirements and no moving parts, yet is self-cleansing and self-activating. An award winning combination that delivers a low maintenance CSO solution and resulting in low whole-life costs.

The Hydro-Jet® Screen can be installed in a purpose built chamber, retrofitted into existing CSO structures, or packaged as a standalone unit.

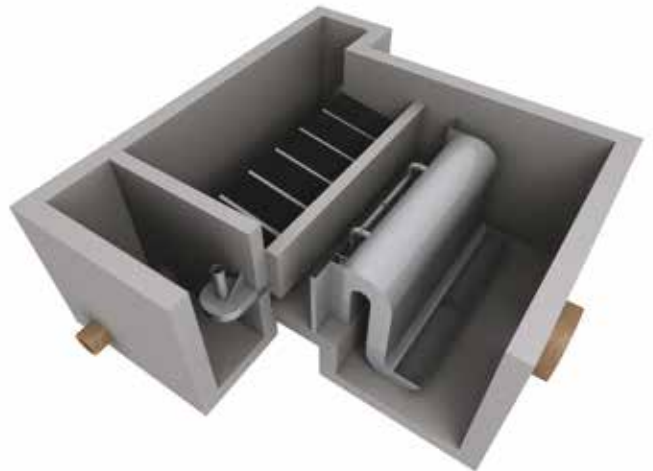

### Applications

- Floatables control for CSOs and collection systems.
- Remote treatment sites.
- New CSO facilities.
- Floatables control for CSOs and collection systems.
- CSO retrofits.

## Heliscreen®

**With low headloss and a small footprint, the Heliscreen® is ideal for retrofit installations with hydraulic or physical site constraints.**

The Heliscreen® is a compact powered CSO screen with the ability to operate under surcharged conditions.

The Heliscreen® is a powered screening system for the removal of floatables, gross solids and other sewer debris greater than 6 mm in two directions.

Heliscreen® is ideal for installation at new or existing CSO facilities where a low maintenance system is required but site constraints, hydraulic levels and/or chamber dimensions preclude the use of Hydro International's non-powered, self-cleansing screens.



### Applications

- New CSO facilities.
- CSO retrofit.
- Storm screen for storm tank applications (before or after storm tank).
- Sites constrained by hydraulic levels or chamber dimensions.
- Facilities with low maintenance requirements.

## Storm King® Overflow

**The system is ideal for satellite treatment at overflow sites and has been shown to save municipalities up to 50% on overall project costs when compared to conventional solutions.**

The Storm King® Overflow with Swirl-Cleanse™ Screen is an advanced hydrodynamic vortex separator with an integral unique, non-powered, self-cleansing screen.

Designed as the ultimate CSO treatment device, the Storm King® with Swirl-Cleanse™ provides screening and removal of gross solids and floatables greater than 6 mm in two directions and removal of sediments, settleable solids and associated pollutants (eg. TSS, BOD and COD).

The Storm King® with Swirl-Cleanse™ is ideal for satellite treatment within the collection system. Installing units at the source reduces the need for increasing conveyance capacity and makes this device an economically viable solution.

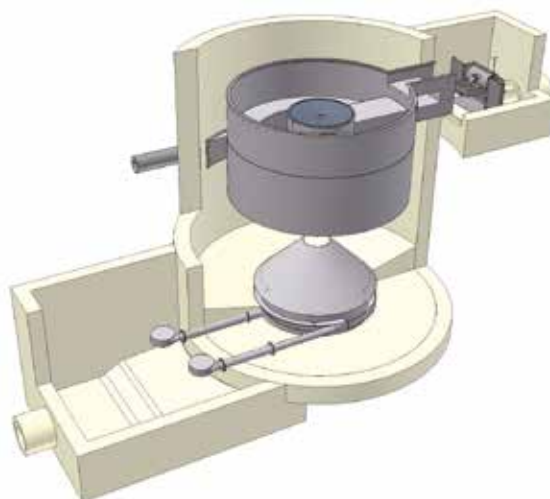

### Applications

- New and retrofit CSO facilities.
- Swirl-Cleanse™ can be retrofit to existing Storm King® Overflows.
- Remote treatment sites.
- Floatables control for CSOs and collection systems.
- Mixing for disinfection.
- Primary treatment equivalency.

## Hydro-Brake® Optimum Vortex Flow Control



### Tight Fit for New Homes

Engineers challenged to solve a “tight fit” surface water management challenge on a West Yorkshire housing development used the Hydro-Brake® Optimum Design Tool to calculate a solution that optimised the limited pipe storage area. Using conventional flow control devices would have required more back up storage than would fit in the space available, but by using Hydro-Brake® Optimum flood protection measures, challenging discharge limits were met for a 1 in 100 year storm.



### ‘Optimum’ Savings for Developer with 21st Century Drainage

The first phase of Edinburgh City Council’s 21st Century Homes project, the Gracemount development showcases sustainable construction. A major feature of the drainage solution is Hydro International’s high performance Hydro-Brake Optimum® to control surface water which saved the developers over 30% in storage construction costs.

## Storm King® Overflow

### Belgian Sanitation Project with Innovative Vortex Technology

A €175m milestone project helping to achieve vital North European water quality targets has been completed following the installation of innovative stormwater treatment technology from Hydro International.

Distributed at-source stormwater treatment is integral to the modernised combined sewer network at Namur in Belgium, with the installation of 33 Storm King® advanced hydrodynamic separators with self-cleansing screens.

The Namur project became fully operational at the end of 2011, providing wastewater treatment for the city’s 125,000 inhabitants and meeting the requirements of the European Water Framework Directive.



## Downstream Defender® Advanced Hydrodynamic Vortex Separator



### Pollution Protection in Whisky Country

Highway degradation and surface water pollution were averted on the A95 near Craigellachie in an environmentally sensitive area of the Scottish Cairngorms thanks to an imaginative SuDS Solution using 3 Hydro-Brake® Flow Controls and a Downstream Defender®.



### Sustainable Homes Infrastructure

The exemplary sustainable drainage infrastructure for the 2300-home Great Kneighton Housing Development in Cambridgeshire is based on a series of four large ponds with infiltration and settling basins located across the 109 hectare site. Downstream Defender® hydrodynamic separators are used to remove sediments, floatables and any hydrocarbons before they reach the ponds. Discharge from the ponds into the receiving watercourse is controlled via Hydro-Brake® Flow Control Devices.

## Up-Flo™ Filter

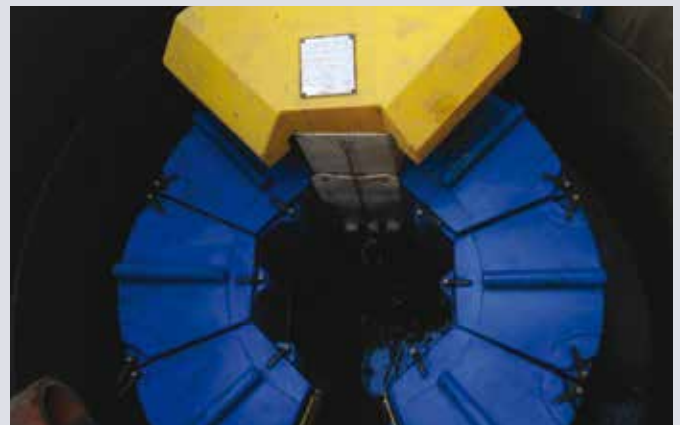

### Natural SuDS 'Not Possible'

A unique solution for a new homes development in Kent enabled SuDS with two levels of treatment for a new access road, combining Up-Flo™ filtration technology with Hydro Stormbloc® modular storage and infiltration blocks.

A custom-modified Up-Flo™ Filter provides effective settlement, screening and filtration to meet Environment Agency water quality requirements while also satisfying the maintenance needs of the highways authority.

To meet the surface water discharge constraints for the site, the final discharge from the filtration unit is infiltrated into the ground using Hydro's modular construction Stormbloc® storage infiltration tank. Because it is load bearing, it could be easily sited under public space in a shallow excavation and landscaped over. This provides around 180 m<sup>3</sup> of storage attenuation and infiltration, without occupying valuable surface area.

## Try the Hydro-Brake Optimum® Design Tool

A free software tool to help engineers fine-tune surface water flood prevention

Try the design tool at:

[www.hydrobrakeoptimum.com](http://www.hydrobrakeoptimum.com)



## Explore the Options with our Treatment Selection Tool

See the results of combining proprietary and natural treatment solutions with our free Treatment Selection Tool.

Try the tool at:

[www.hydro-int.com/stormtrain/tool](http://www.hydro-int.com/stormtrain/tool)



## Hydro International

Shearwater House  
Clevedon Hall Estate  
Victoria Road  
Clevedon  
BS21 7RD

Tel: 01275 878371  
Fax: 01275 874979

[www.hydro-int.com](http://www.hydro-int.com)

Turning Water Around...®