

# REINFORCED CONCRETE CHANNELS K 400 SERIES

Grating width 400 mm

Reinforced concrete channel and GJS500-7 ductile iron grating equipped with locking system complying with the UNI EN 1433 standard. The channels are sold exclusively in complete pallets and together with the gratings.

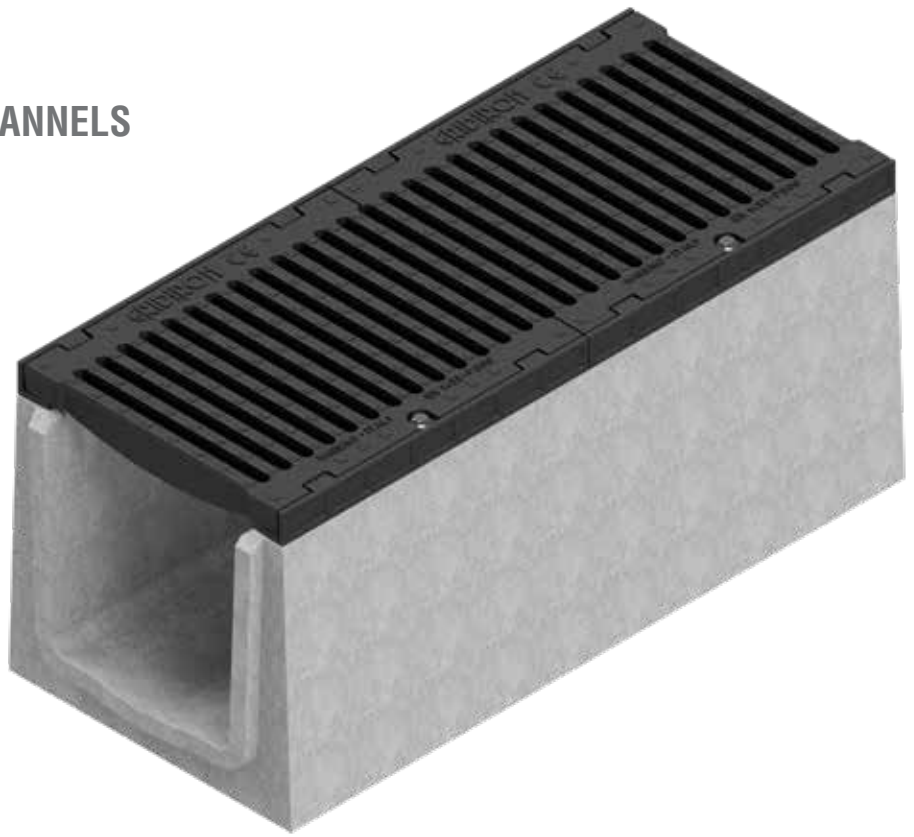

## K 400 Series channel dimensions

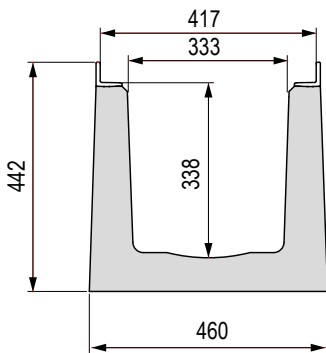

## Available grating



GJS500-7 ductile iron grating  
**F 900**

## K 400 Series channel complete with grating - Length 1,000

Channel L mm	Code	Description	Water passage mm	Run-off section cm <sup>2</sup>	Weight kg	Pieces pallet	Price €	Load class
1,000	4K10S	Reinforced concrete channel with 400 mm grating made of GJS500-7 ductile iron	333	977	302	6	613.27	F 900

## K 400 Series channel accessories

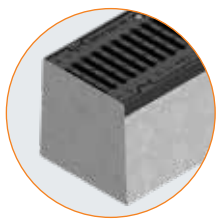

Right-hand end cap

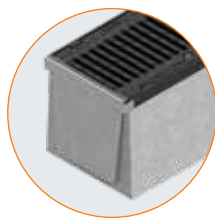

Left-hand end cap

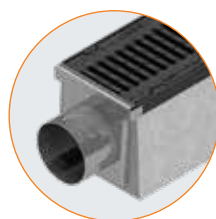

End caps with outlets

Code	Accessories	Weight kg	Price €
4K10TID	Right-hand end cap for channel closure female side	1.36	40.12
4K10TIS	Left-hand end cap for channel closure male side	1.36	40.12
4K10RI	End cap with outlet Ø 204 mm	2.80	67.80
4K10SF	Channel with perforated bottom Ø 202 mm	298.00	690.66