

REINFORCED CONCRETE CHANNELS

C 500 SERIES

Grating width 500 mm

Reinforced concrete channel with galvanised edge rails complying with the UNI EN 1433 standard. The channels are sold exclusively in complete pallets and together with the gratings.



C 500 Series channel dimensions

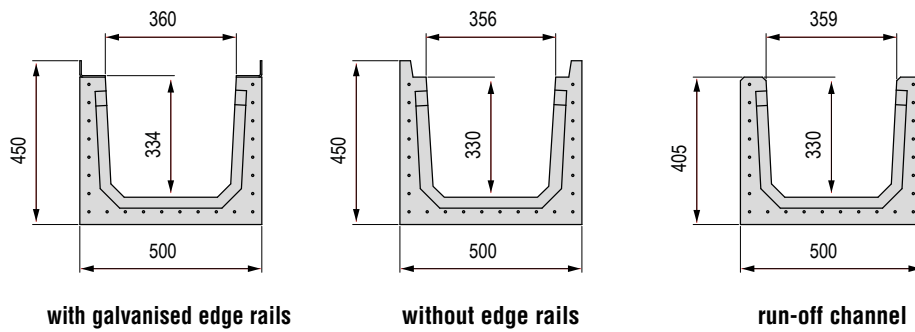

Available gratings N.B.: the concrete cover is available only on request

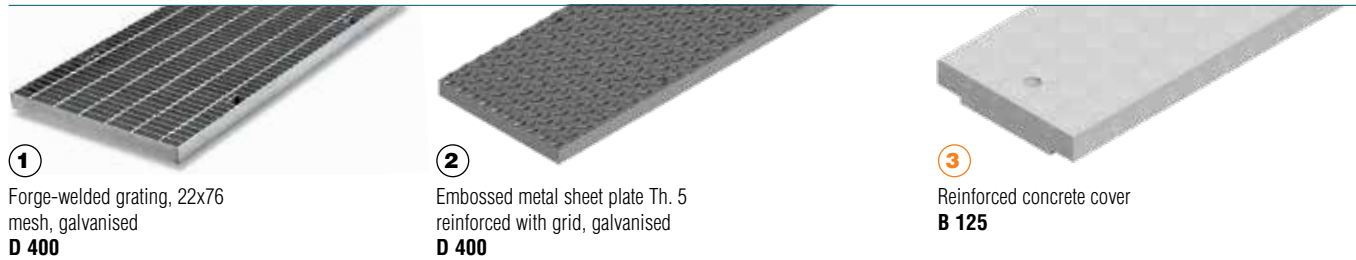

Grating L mm	Code	Grating	Description of the gratings complete with accessories for C 500 channel	Weight kg	Price €	Load class
1,000	4W00G	①	Forge-welded galvanised grating 40x4 22x76 complete with stainless steel nuts and bolts	31.90	243.49	D 400
	4W00P	②	Embossed metal sheet plate Th. 5 reinforced with galvanised grid, complete with stainless steel nuts and bolts	35.50	251.83	
	4WA0C	③	Solid reinforced concrete cover only for water run-off channel	75.00	81.95	B 125

C 500 Series channel without grating

Channel L mm	Code	Description	Water passage mm	Run-off section cm ²	Weight kg	Pieces pallet	Price €
2,000	4W01S	Reinforced concrete channel with galvanised edge rails (combine with 2 gratings or plates L=1,000 mm)	360	1099	478	4	545.36
	4WN1S	Reinforced concrete channel without galvanised edge rails (combine with 2 gratings or plates L=1,000 mm)	356	1099	488	4	314.34
	4WA1S	Reinforced concrete water run-off channel (combine with 2 reinforced concrete covers L=1,000 mm)	359	1099	468	4	299.04
1,000	4W00S	Reinforced concrete channel with galvanised edge rails	360	1099	239	6	401.80
	4W00N	Reinforced concrete channel without galvanised edge rails	356	1099	244	6	196.12
	4WA0S	Reinforced concrete water run-off channel	359	1099	234	6	180.81

ADDITIONAL PROCESSING ON REQUEST

Code	Accessories	Weight kg	Price €
	Channel bottom drilling Ø 202 mm		77.39